

FREEDM SYSTEMS CENTER

Challenges and Recent Breakthroughs in the Stability
and EMT Simulation of Large-Scale Power Systems

Hantao Cui, Associate Professor

02/10/2026

hcui9@ncsu.edu

- Computer-based simulations are widely used for engineering decisions
- Two categories of problems for transmission systems
 - Can generators remain in synchronism after a **large disturbance**?
 - What are the instantaneous voltages and currents following **abrupt** changes in network topology or device states?
- Known as **transient stability** and **electromagnetic transient** problems
- Two families of software have been developed
 - Transient stability simulators: PSS/E, PowerWorld, DSATools TSAT, etc.
 - Electromagnetic transient simulators: PSCAD/EMTDC, EMTP, ATP, XTAP,

- Transient stability and EMT problems **share the same mathematical root**
- Transient stability solves switched differential-algebraic equations

$$(\dot{x}, 0, q^+) = (f, g, h)(x, y, q)$$

- EMT solves switched differential equations

$$(\dot{x}, q^+) = (f, h)(x, q)$$

Why two families of tools?

- **different assumptions have been made**
- **specialized solution methods** have been developed that have been proven effective

That resulted in different roles in power system planning and analysis.

- Transient stability problems are slowed down by the problem **size**
- Assuming **network steady state**, the network equation ($I=YV$) is solved **separately** from machine dynamics
 - Numerical stability issues were not pronounced in the early days when models were simple and continuous
- For controllers with **implicit algebraic equations**, *ad hoc* iterations are required by assuming other variables are fixed
 - It causes convergence difficulties when controller dynamics are fast

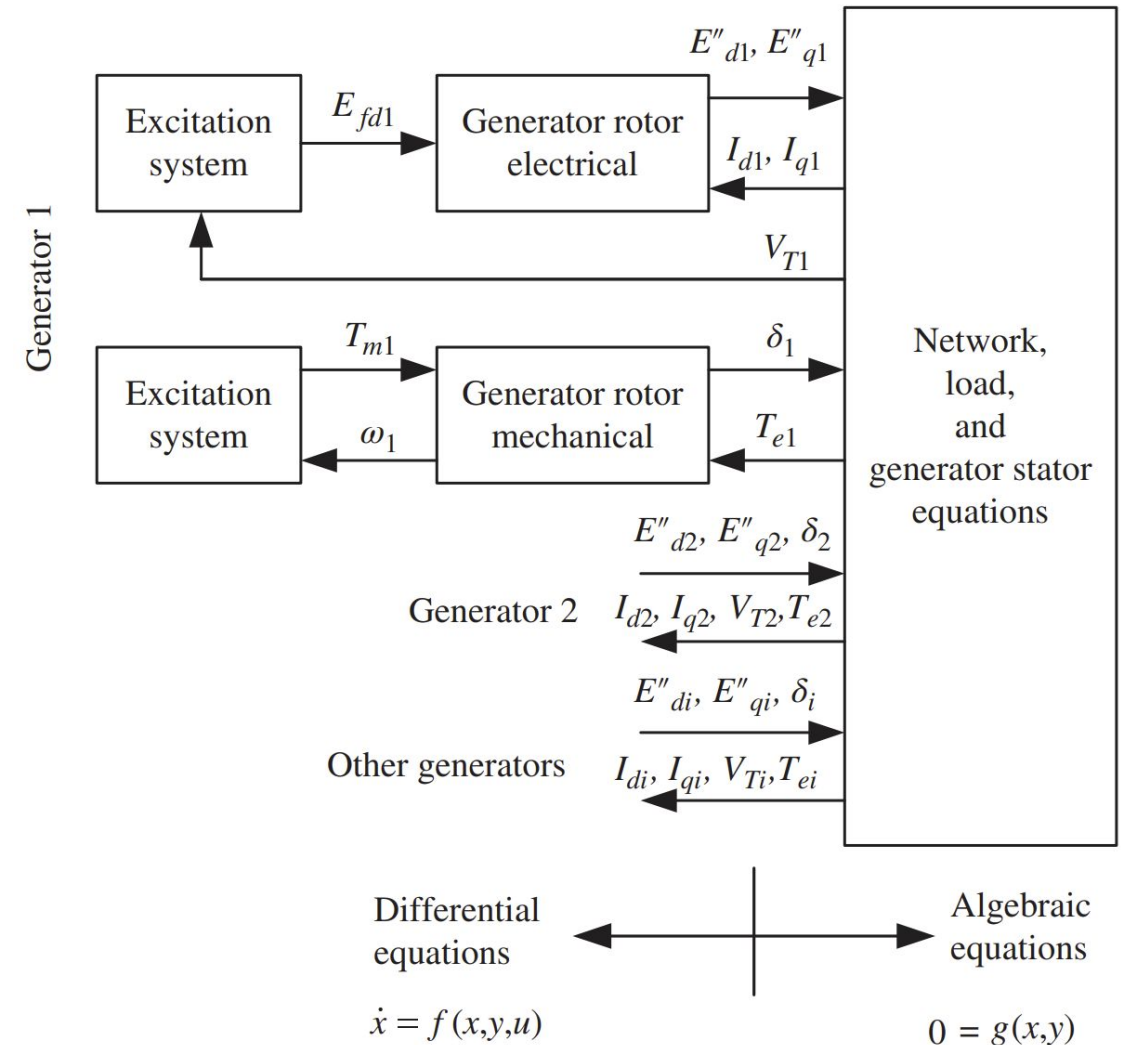

- EMT Programs are slowed down by the **small step size** required to capture fast dynamics
 - Numerical stability is critical because circuits may have low damping
 - Implicit methods are preferred, but updating Jacobian matrices is slow and hard to program
- A “numerical integration substitution method” (also known as Dommel’s method) is widely adopted
 - But if a generic component’s G depend on the network voltage, algebraic loops are formed

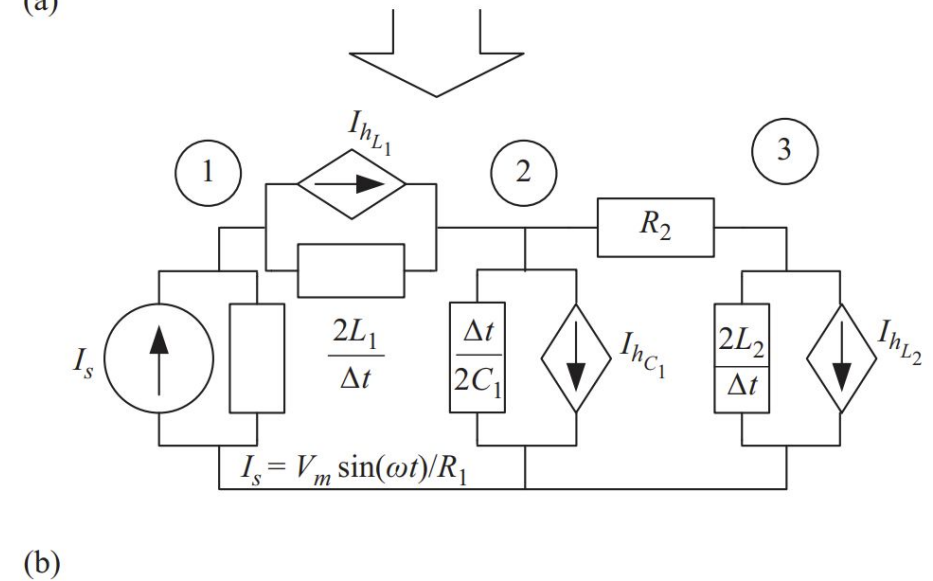
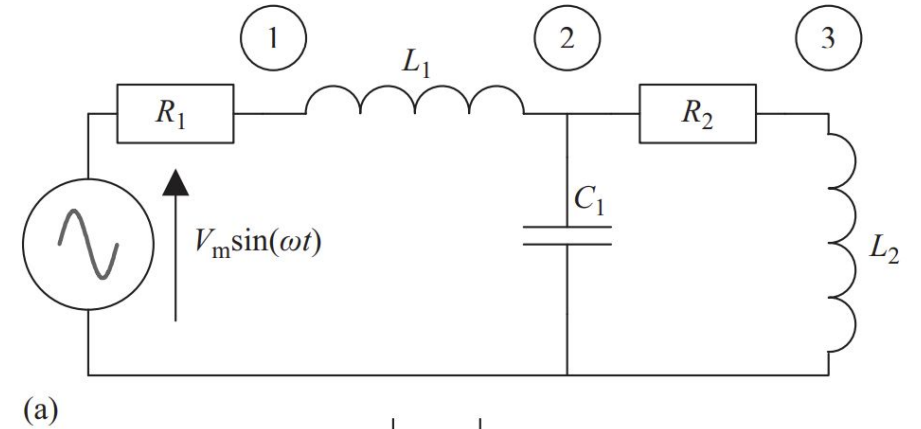

Watson, Arrillaga, *Power Systems Electromagnetic Transients Simulation-Institution of Engineering and Technology* (2019)

- Inverter-based resources challenge both types of programs
 - **Convergence issues** for transient stability programs due to algebraic loops and discontinuity
 - **Slow computational speed** for EMT programs due to the assumed fixed step size (to keep \mathbf{G} constant)
- Can we go back to the original mathematical formulation and solve the DAEs and ODEs in their native form?
 - Power flow solution as the boundary condition for transient stability at steady state
 - Can we use transient stability initialization as the boundary condition for EMT problems?

- Same boundary condition
- Augmentation of transient stability data for EMT simulation
- Interface with general-purpose ODE solvers

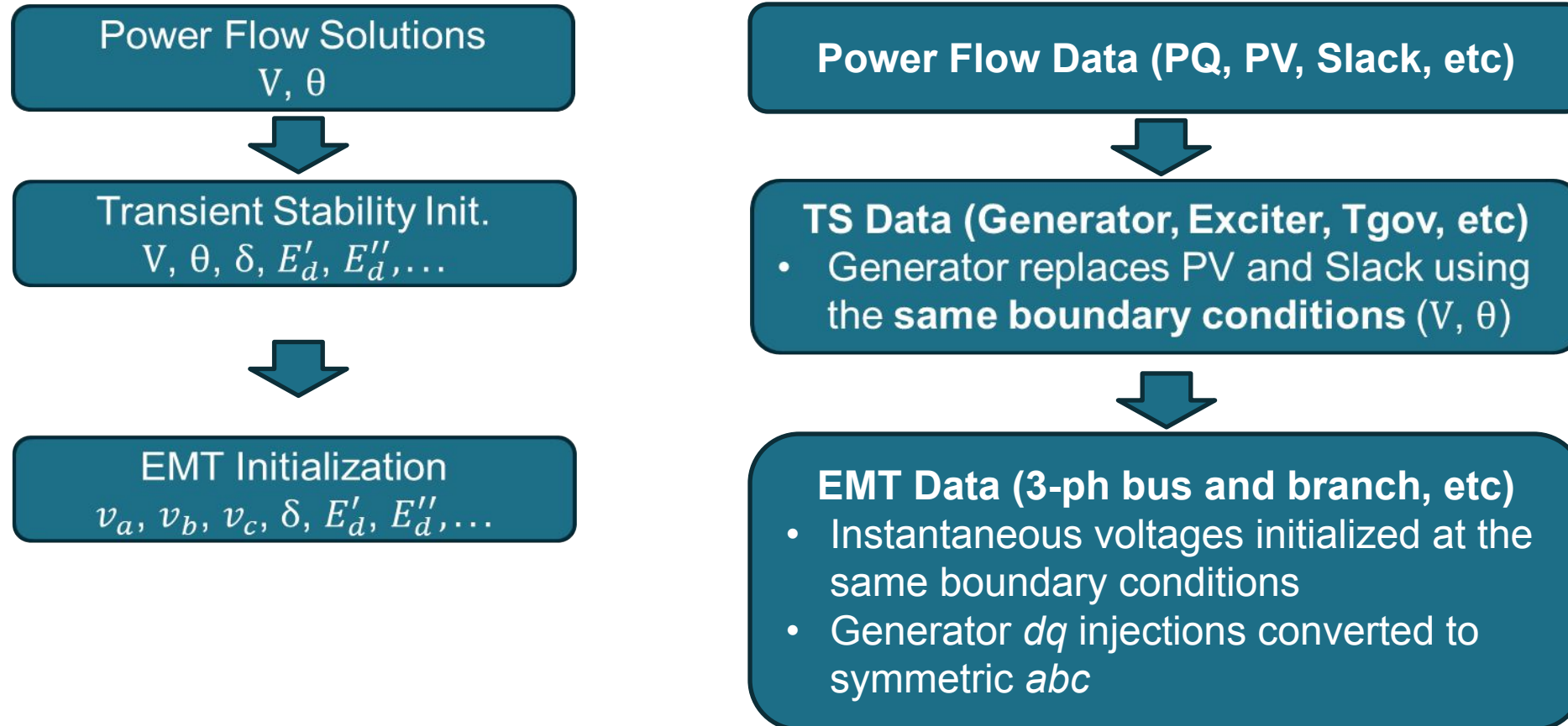

EMT vs Phasor Comparison - ieee14 - Bus 10 Fault (xf=0.01)

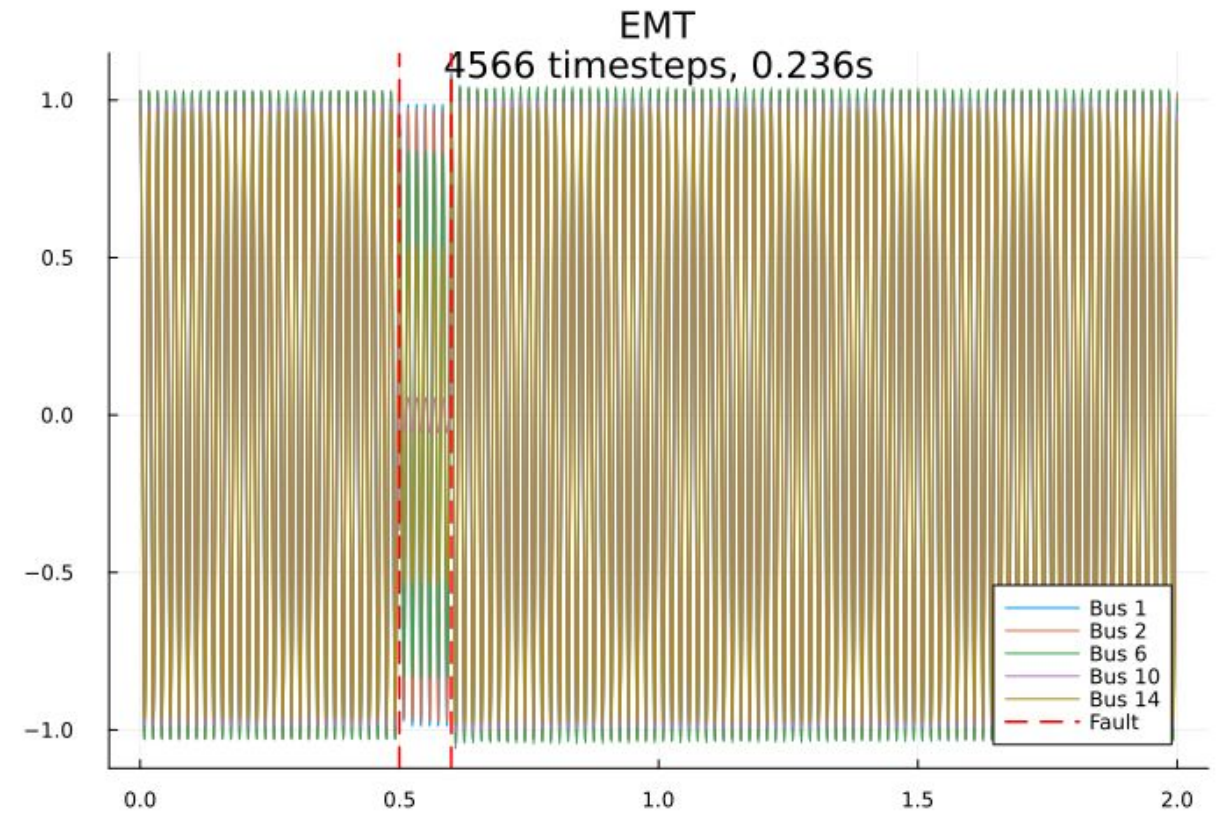
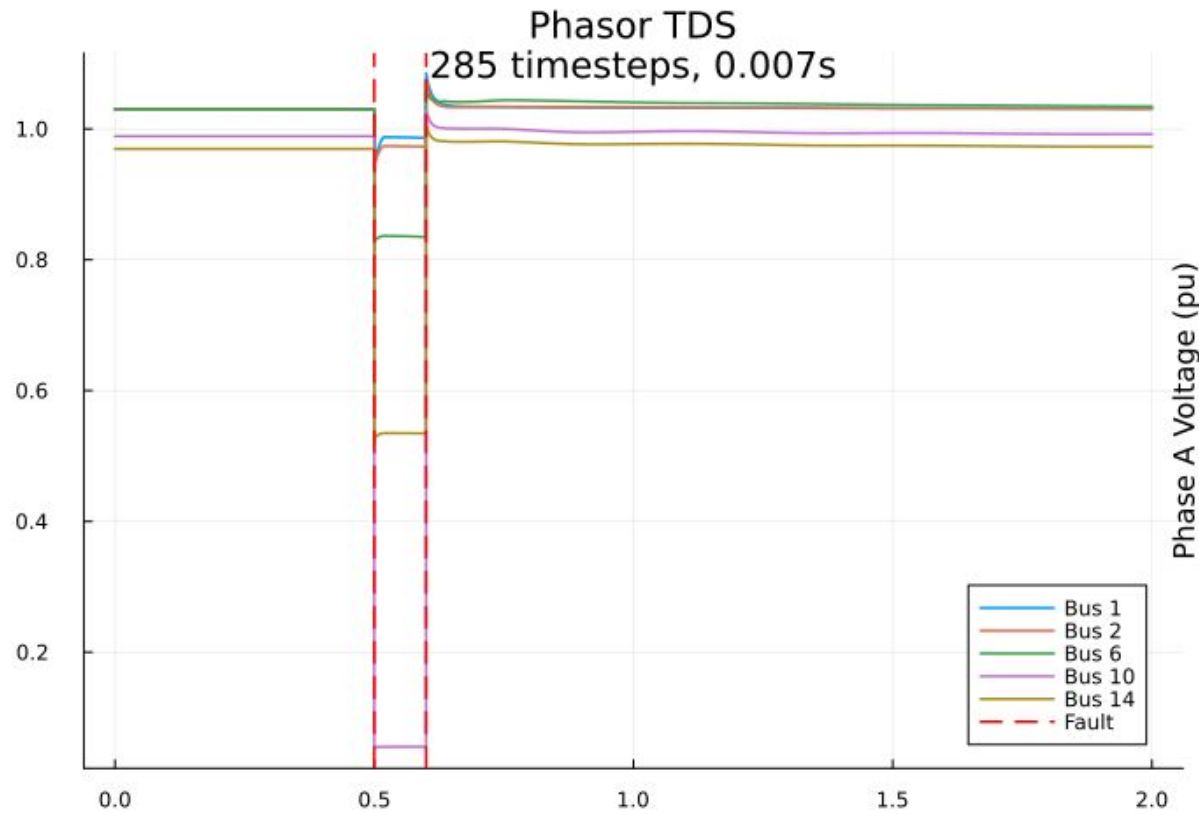

Generator Speed Comparison - ieee14

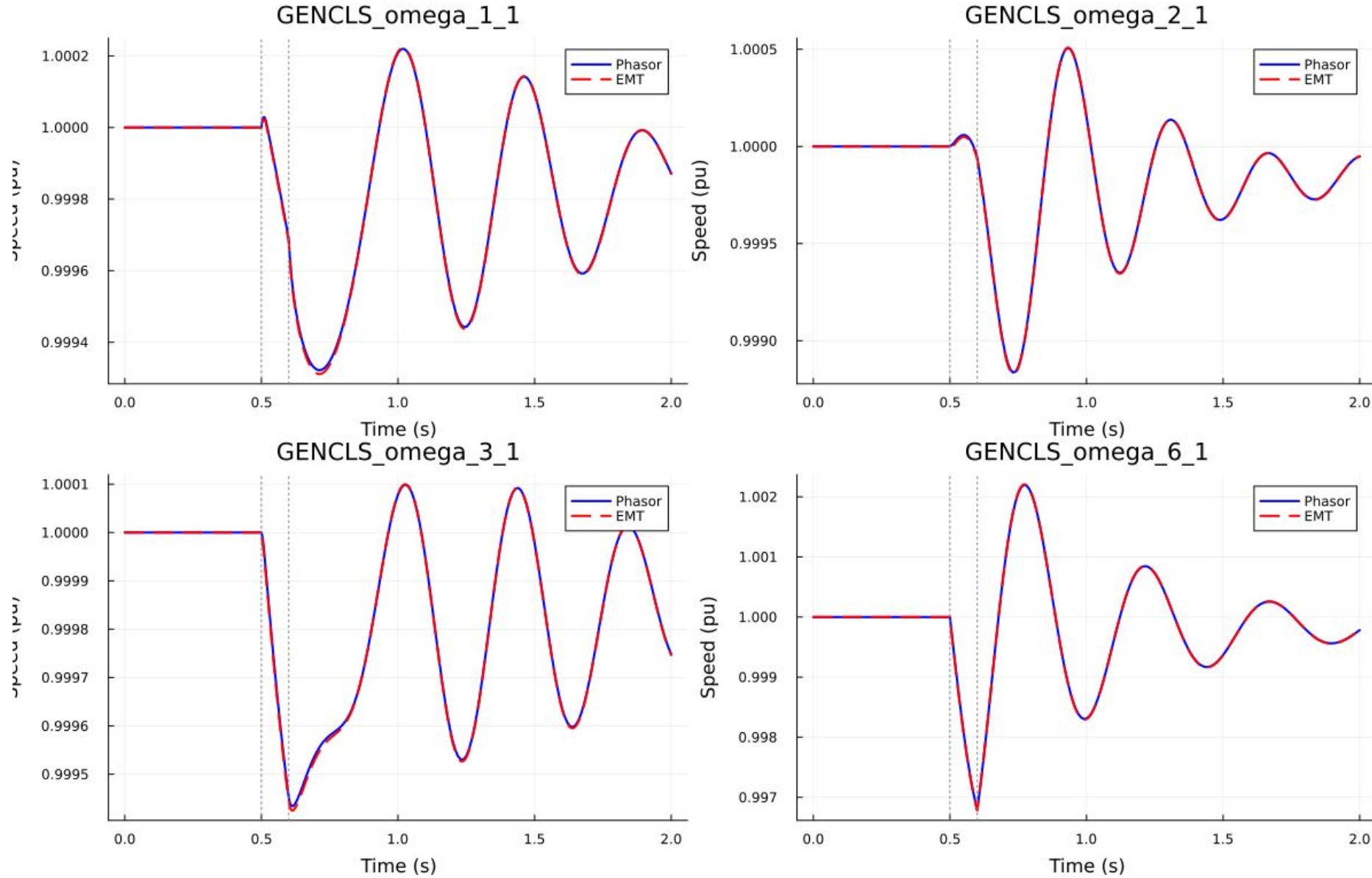

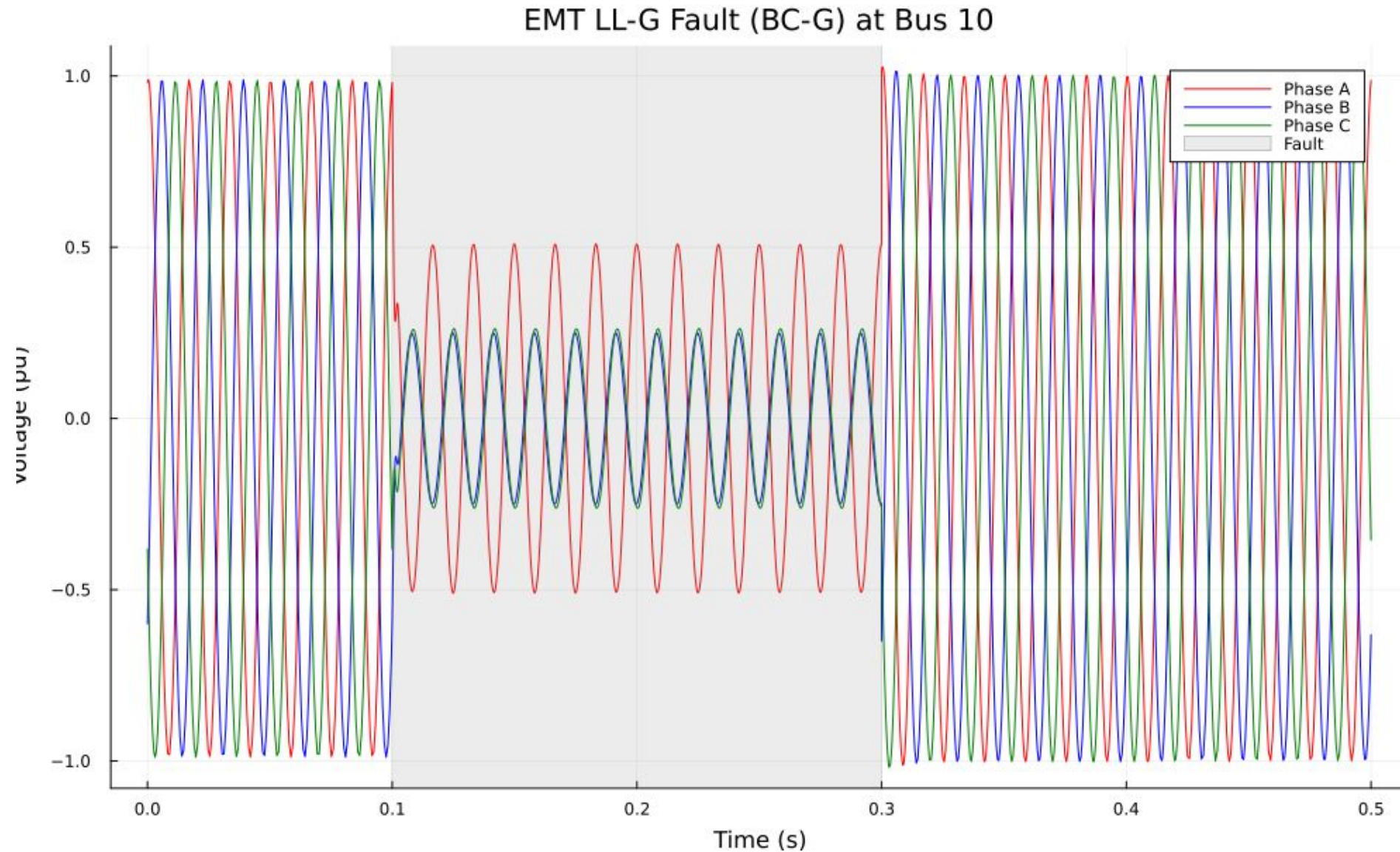

- Transient stability and EMT programs rely on fundamentally different assumptions, which limit their robustness and scalability in modern power systems
- IBRs expose convergence and efficiency issues in both phasor and EMT-based simulations
- Revisiting the original DAE and ODE formulations enables consistent initialization and tighter coupling between transient stability and EMT analysis
- Unified modeling and simulation frameworks are essential for accurate and efficient studies of future large-scale power systems