

# **High-Power SiC Inverter with Ultra-High Efficiency For Transportation Applications**

**Wensong Yu, [wyu2@ncsu.edu](mailto:wyu2@ncsu.edu)**

**NC State University**

# Opportunities & Challenges of SiC verse Si Inverters for Transportation Applications

- ❑ Much better efficiency and power density
  - SiC-MOSFET effectively reduces switching loss and conduction loss at partial load compared to Si-IGBT
  - SiC-MOSFET enables high efficiency, high power density and high frequency operation

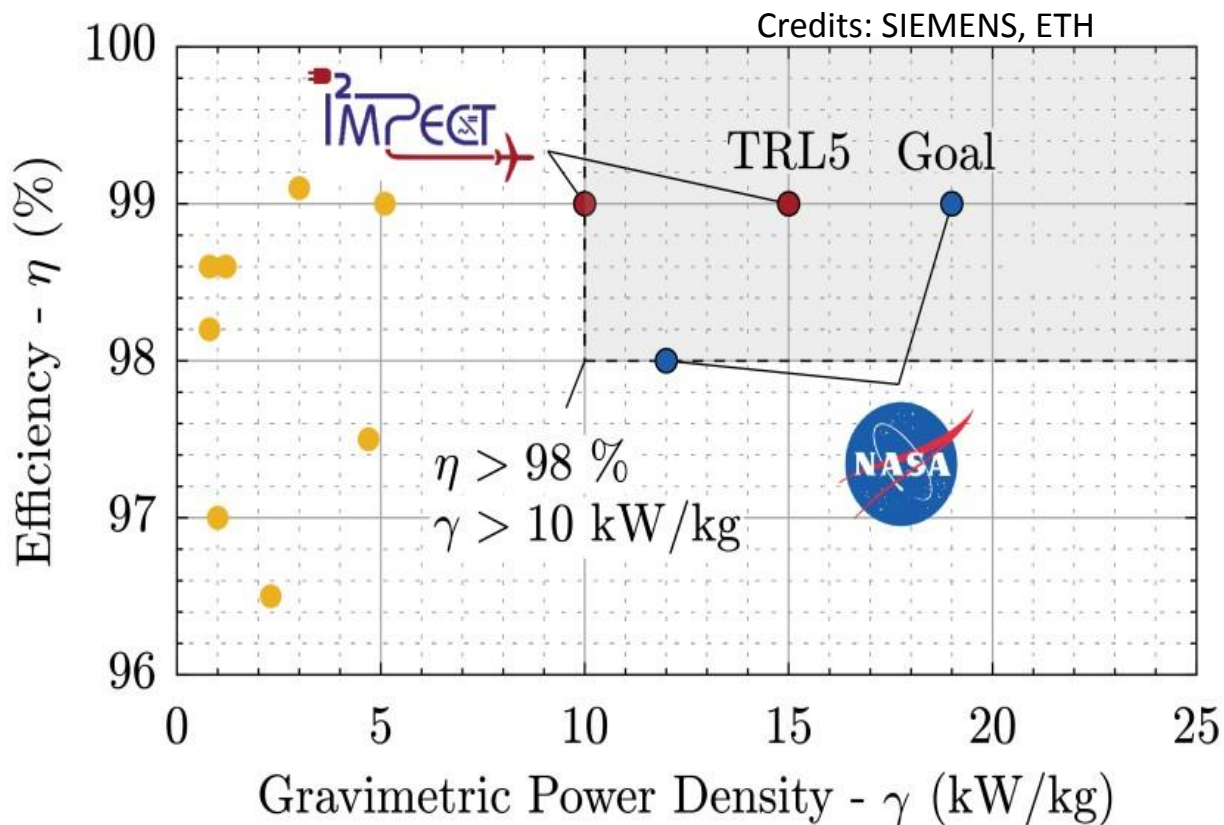

- ❑ Extremely high dv/dt challenge
  - Si-IGBT:  $dv/dt = 2-6$  kV/ $\mu$ s
  - SiC MOSFET:  $dv/dt = 20-60$  kV/ $\mu$ s
  - Issues: motor insulation stress, bearing current, EMI

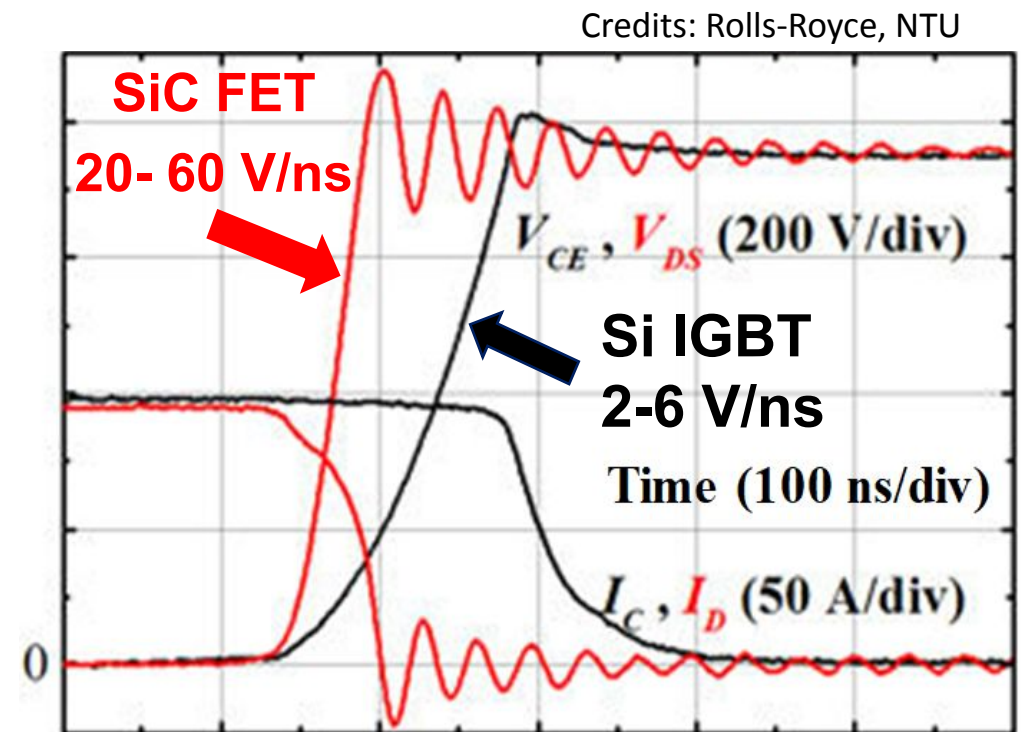

# Overview of Proposed Solution

---

## Objectives:

- The objectives of this project are twofold:
  - **To extend the power level of SiC inverter and dv/dt filter up to 200 kW**
  - **To simplify the gating control, improve robustness and reduce cost**
- These goals will be validated by developing a SiC inverter with
  - **99.5% or higher peak efficiency, and**
  - **Better (less) than 6 kV/ $\mu$ s voltage slope**

## Expected Outcomes and Impacts:

- 50% total power loss savings compared with hard-switching SiC motor drives
- Ensured dv/dt compatibility with NEMA standards (NEMA MG 1-2016, Part 31)
- Minimized stress on motor insulation with longevity of the electric motor
- Improved EMC, better noise immunity of sensors, gate drivers and controllers
- Simplified thermal management, easier integration of inverter and motor
- Reduced motor loss with the increased frequency of the inverter

# Technical Method of Proposed Solution

- Active small dv/dt filter (shown **in green**) operates in a very short time ( $< 1\mu\text{s}$ ). Its RMS current is **7X** lower than the current stress of the main circuit (shown **in red**).
- All main switches (shown **in red**) operate at nearly perfect zero-voltage-switching under any input voltage, any output voltage and current conditions with significantly reduced switching loss
- Using the simple gating signals (shown **in black**), as simple as signals in classic 2-level inverters

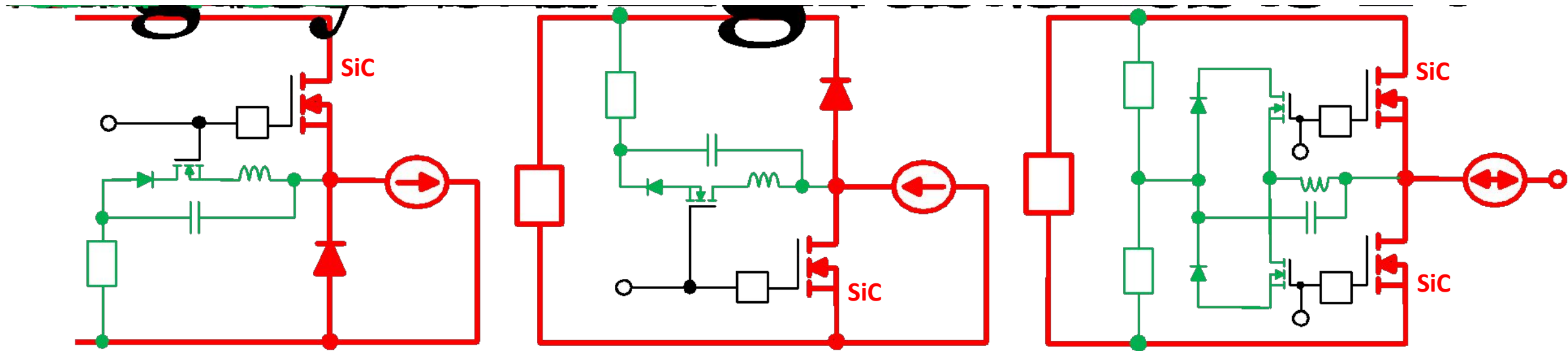

# 10X dv/dt Filter Volume Reduction

- For classic dv/dt filter, the bulky inductor is connected in series with load. Lossy damping resistor  $R_d$  is needed.
- For state-of-art dv/dt filter, lossy damping resistor  $R_d$  is deleted with penalty of the triple gating.
- For proposed dv/dt filter, the inductor is connected in parallel with load. **Inductor current remains zero for >90% time.** The filter volume is reduced around 10 times compared to the existing solutions.

## Classic dv/dt filter

X Lossy damping  $R_d$

X Bulky inductor  $L_r$

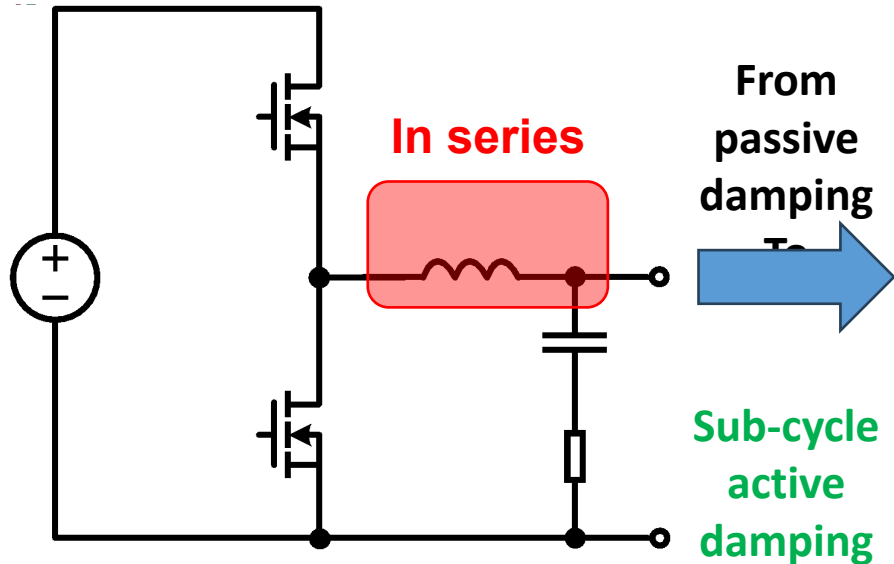

## State-of-art dv/dt filter

✓ No  $R_d$

X Bulky  $L_r$

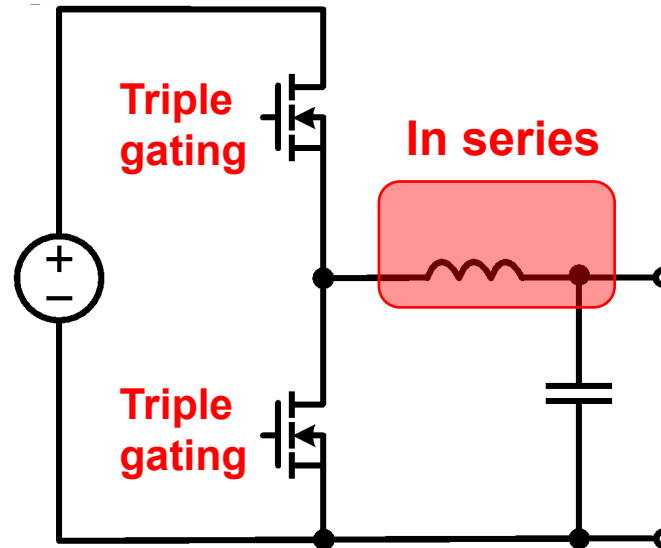

## Proposed dv/dt filter

✓ No  $R_d$

✓ Small  $L_r$

10X reduced filter volume!

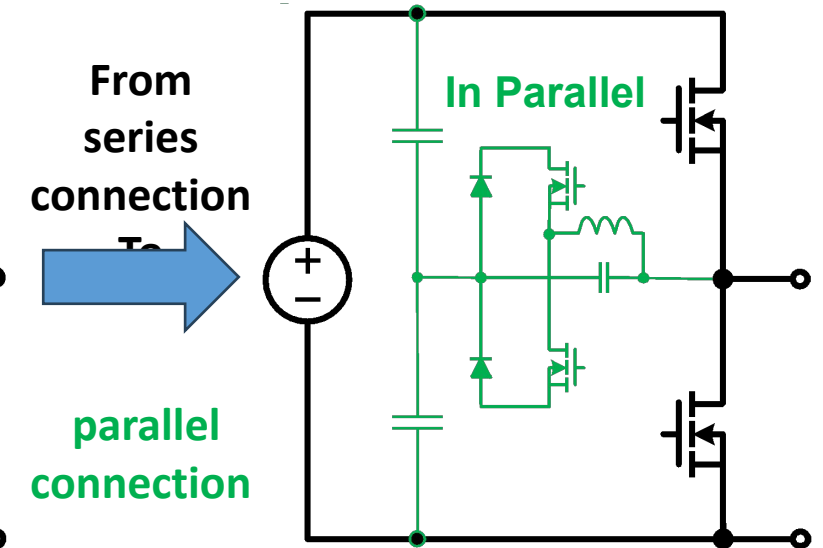

# 7.6 X Reduction of Inductor Current RMS

- Because of the proposed dv/dt filter with parallel configuration, conduction duration of the inductor reduces more than 50 times compare to the existing dv/dt filter solutions with series configurations.
- RMS current of the inductor is 34 A in the proposed filter at 200 kW power and 18kHz switching frequency, which is a 7.6 times reduction compared to the 261A RMS current in the classic and state-of-art solutions .

@ Motor fundamental cycle (60Hz)

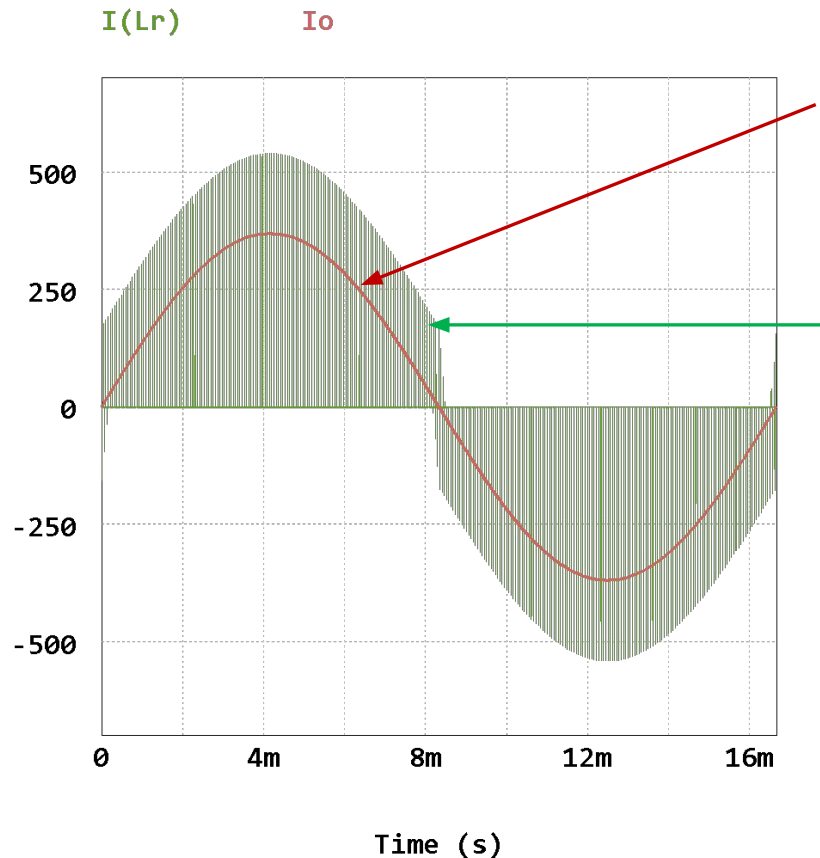

@ SiC FET switching cycle (18 kHz)

Existing filter current  
Proposed filter current

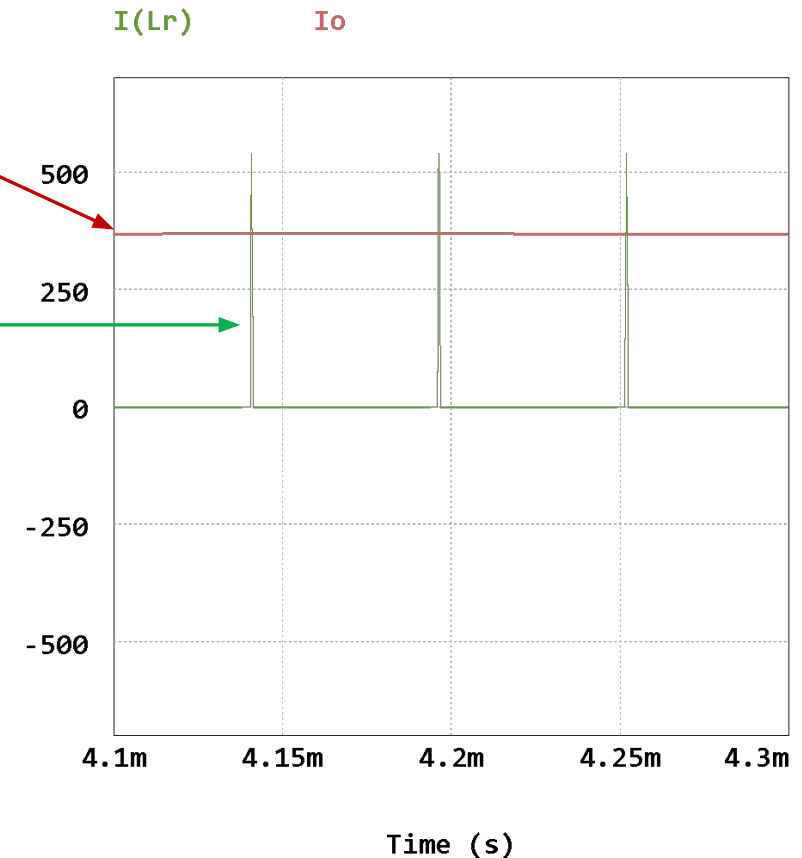

# Significantly Reduced Switching Loss

- Classic dv/dt filter requires bulky and lossy damping resistors to dissipate the extra oscillation energy.
- State-of-art dv/dt filter eliminates the damping resistor but triples the switching loss.
- The proposed dv/dt filter can not only recover the energy in the filter but also significantly reduce the switching loss of the main switch in the high-power inverter.

## ▪ Classic dv/dt filter

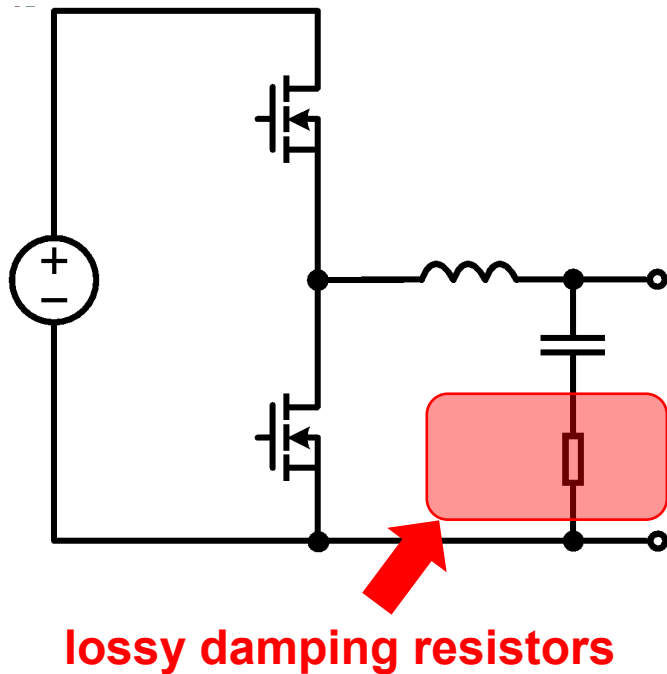

## ▪ State-of-art dv/dt filter

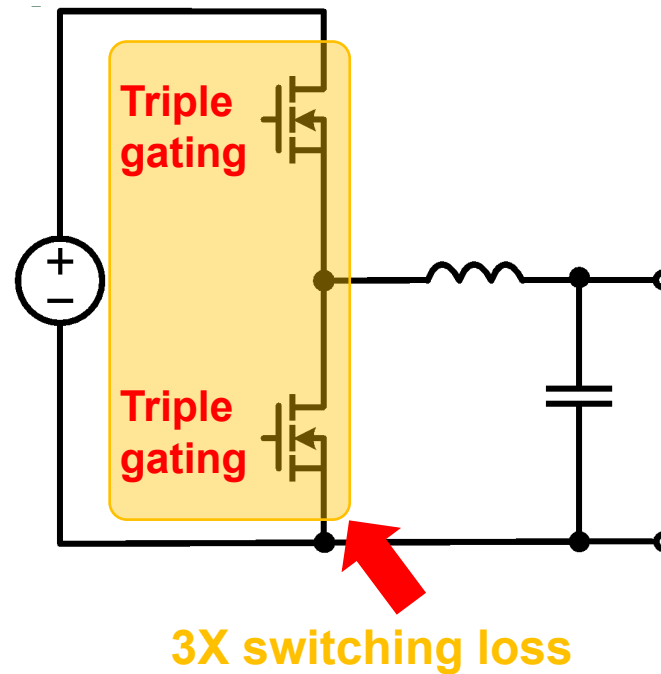

## ▪ Proposed dv/dt filter

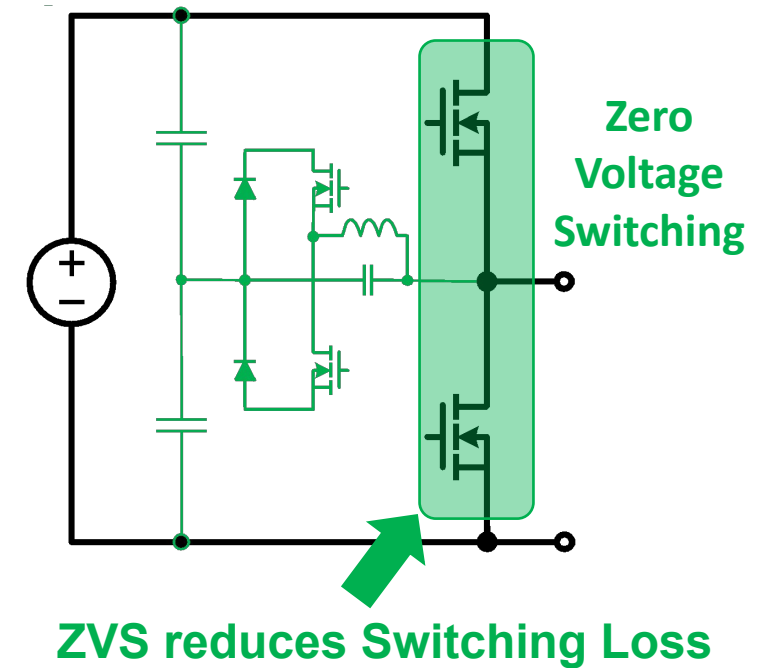

# More Than 50% Total Power Loss Savings

- 200 kW SiC inverter with series inductor and damping resistor dv/dt filter dissipates the extra 347 W power loss. The total loss of this inverter is estimated at 1564 W.
- 200 kW SiC inverter with state-of-art dv/dt filter no need of damping resistor and triples the switching loss. At 18kHz, the total loss of the inverter is estimated at 2459 W.
- Total power loss of inverter with the proposed soft-switching dv/dt filter is estimated at 769 W with >50% savings.

SiC Inverter with dv/dt Filter	Main switch switching loss (W)	Main switch conduction loss (W)	Resistor Loss (W)	Inductor Loss (W)	Auxiliary switch conduction loss (W)	Auxiliary switch switching loss (W)	Total Loss (W)
<b>The classic</b>	<b>556</b>	626	<b>347</b>	35	0	0	<b>1564</b>
<b>The state-of-art</b>	<b>1687</b>	727	0	45	0	0	<b>2459</b>
<b>The proposed</b>	<b>71</b>	573	0	25	90	9	<b>769</b>

# Three-Dimensional Design of SiC Inverter with dv/dt Filter

## □ Single-phase SiC inverter parameters

Lr: 0.33  $\mu$ H,      Cr: 47.6 nF  
Sa: 2X TO247-4,    1.2 kV/16 m $\Omega$   
Da: 2X TO247,     0.75 V/100 A  
Sm: Half-bridge,    SiC 1.2 kV/3.1 m $\Omega$

## □ Three-phase 200kW SiC inverter parameters

Rated DC voltage: 800V  
Three-phase current: RMS 250A  
Three-phase voltage (P-to-N): RMS 270V  
Switching frequency: 18 kHz

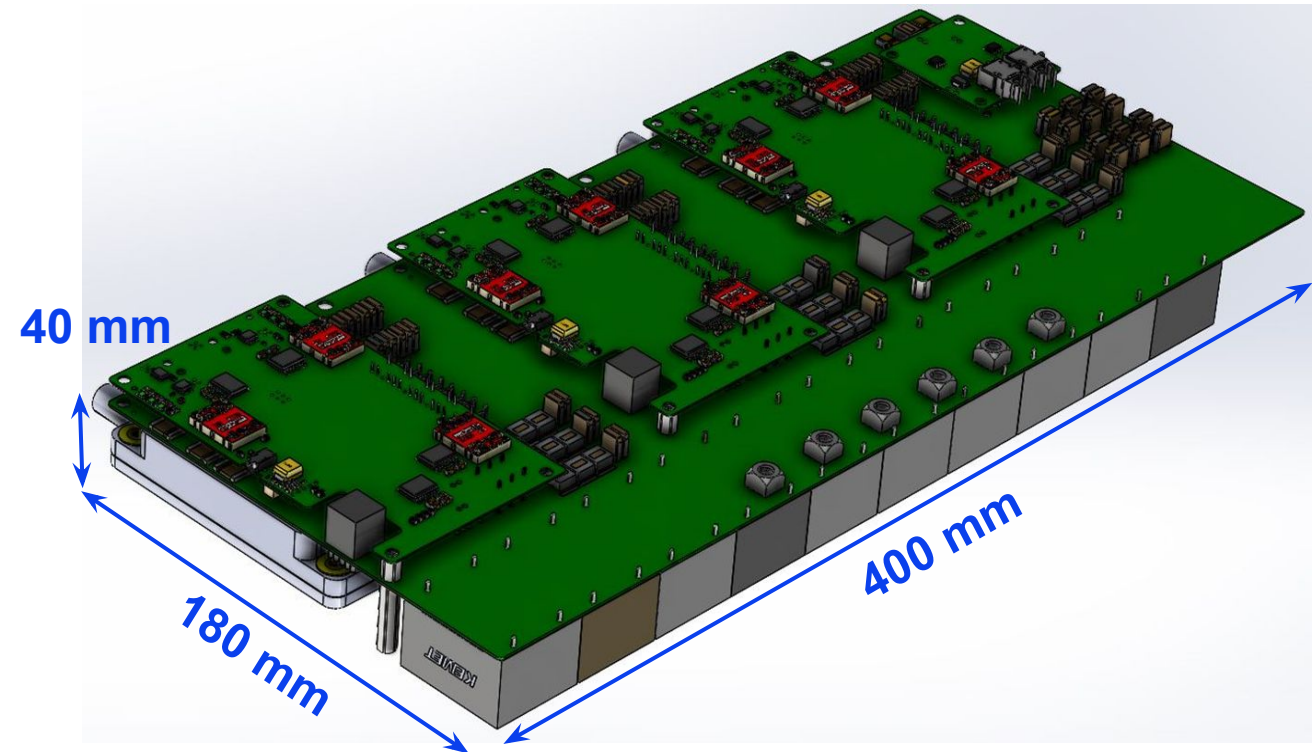
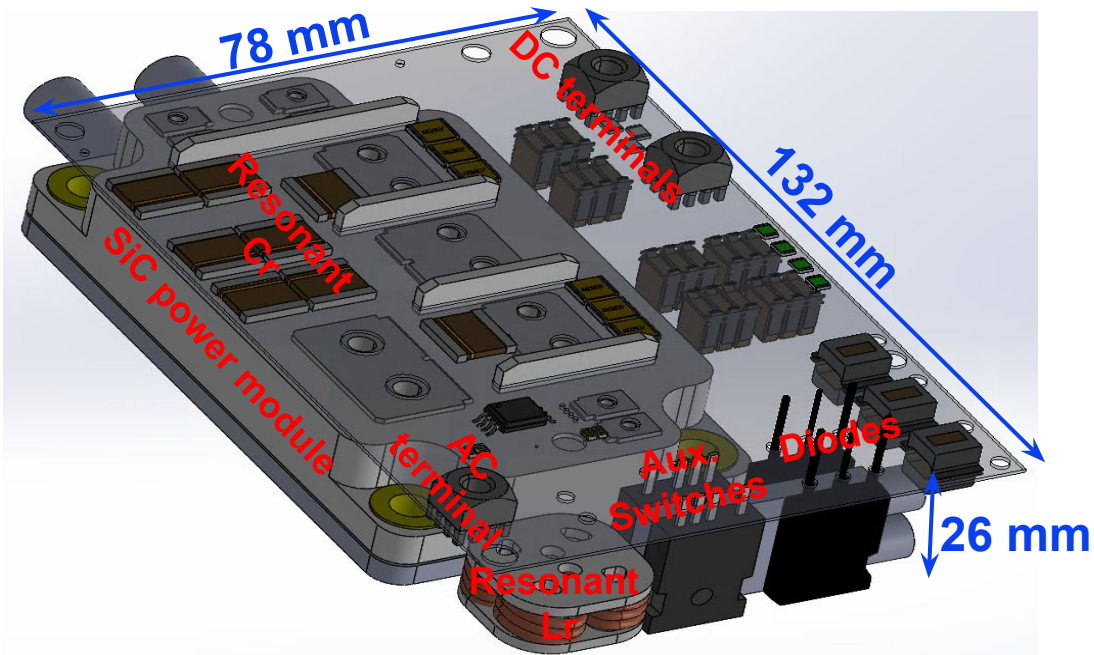

# Test Results of Voltage Slope Control

- The voltage slope  $dv/dt$  at rising and falling edges has been confirmed to remain below 6 V/ns even under the full range of AC load current and DC bus voltage conditions.

- Voltage slope at zero load

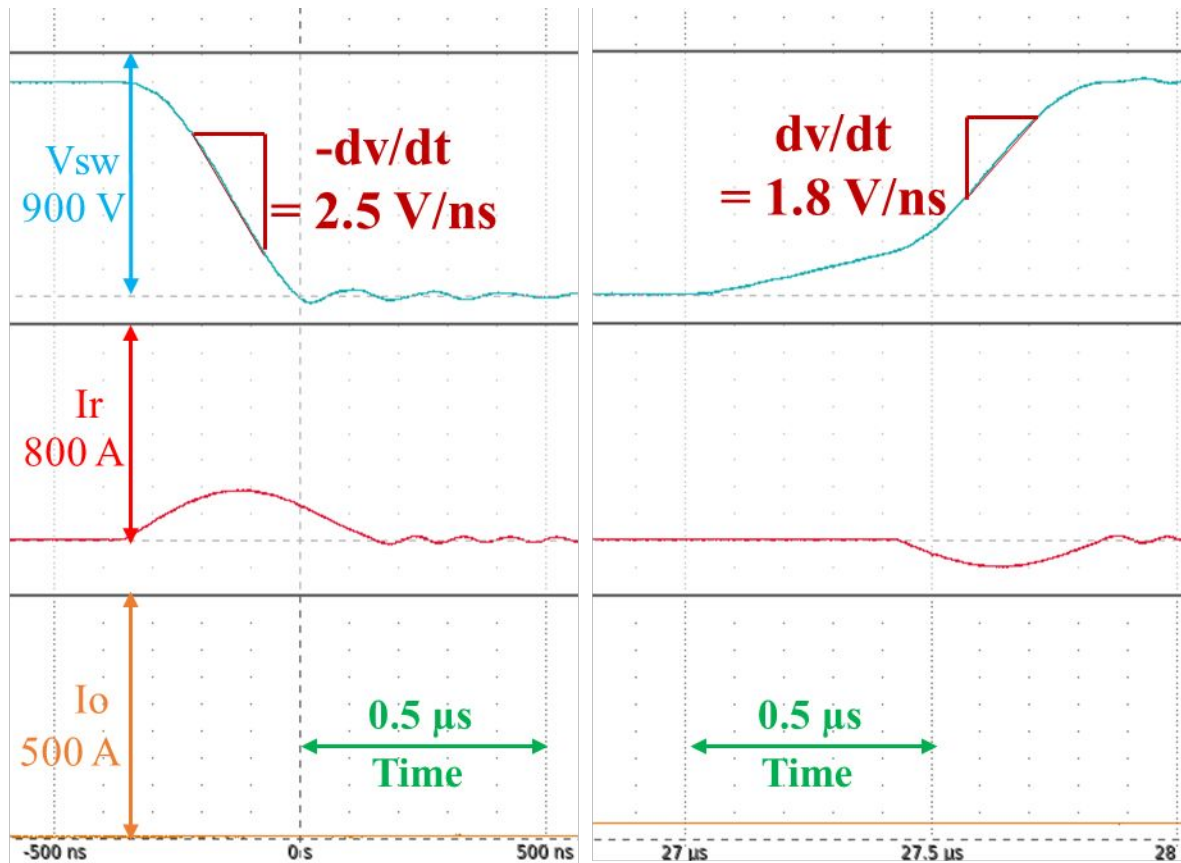

- Voltage slope at full load

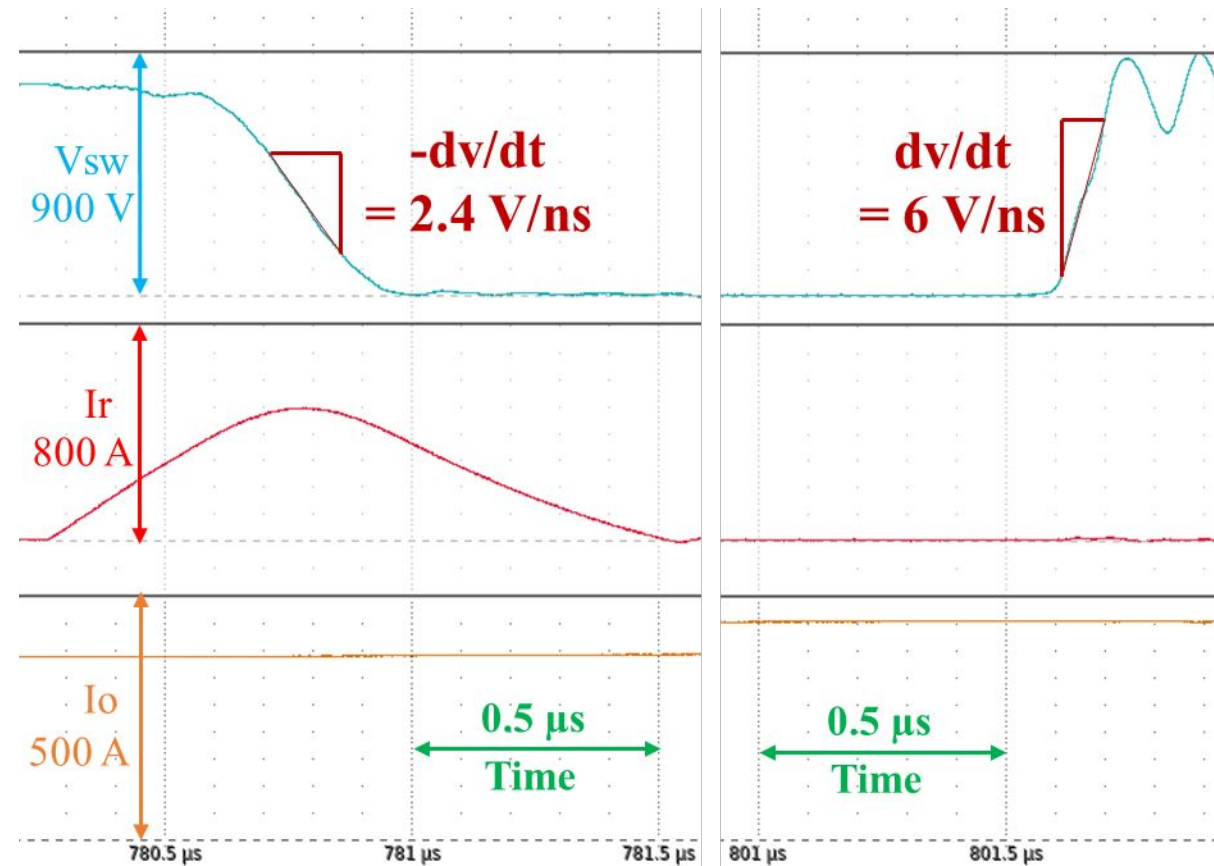

# High-Precision Efficiency Measurement

## Mathematical analysis of efficiency accuracy

Based on efficiency definition  $\eta = \frac{P_o}{P_o + P_{loss}}$

And the product rule of derivatives  $\Delta(xy) = x(\Delta y) + y(\Delta x)$

We can mathematically prove

$$\text{Efficiency relative error } \frac{\Delta\eta}{\eta} = \left( \frac{\Delta P_o}{P_o} - \frac{\Delta P_{loss}}{P_{loss}} \right) (1 - \eta)$$

When efficiency ( $\eta$ ) reaches 0.995, the accuracy of efficiency measurement is enhanced by **200 times** by measuring the output power and power loss instead of input power!

In a back-to-back configuration, it is possible to directly measure the power loss of the inverter. An efficiency error of below  $\pm 0.01\%$  is achievable when the efficiency ( $\eta$ ) is 99.5%.

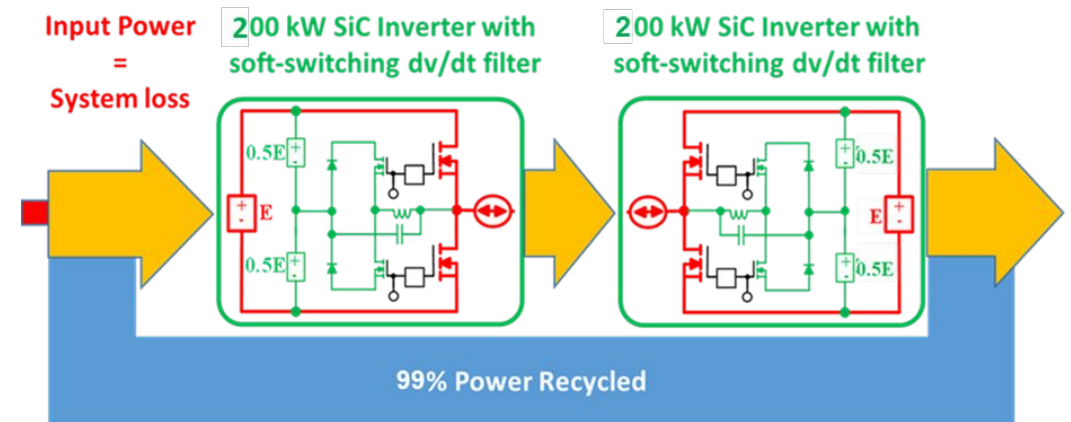
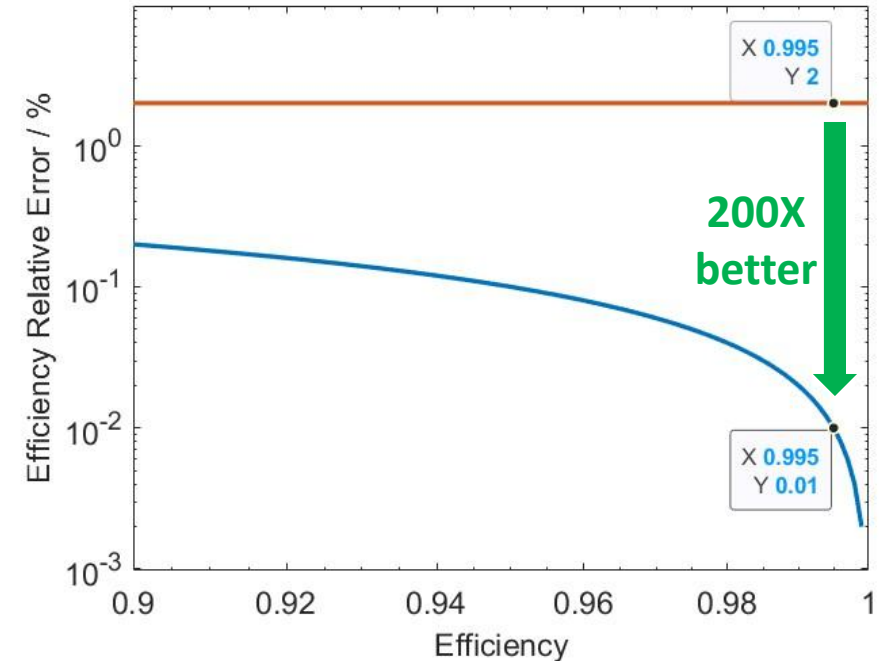

# Ultra-High Efficiency at 203 kW Full Power

High accuracy ( $\pm 0.01\%$ ) efficiency measured by the power analyzer and the back-to-back regenerative method for two identical three-phase inverters including dv/dt filters

- 99.60% efficiency at 203 kW

$$\eta = \frac{P_o}{P_o + P_{loss}}$$

$$= \frac{203226}{203226 + 818}$$

$$= 99.60\% \pm 0.01\%$$

- 800 Vdc, 18 kHz switching frequency, and 500 Hz output frequency

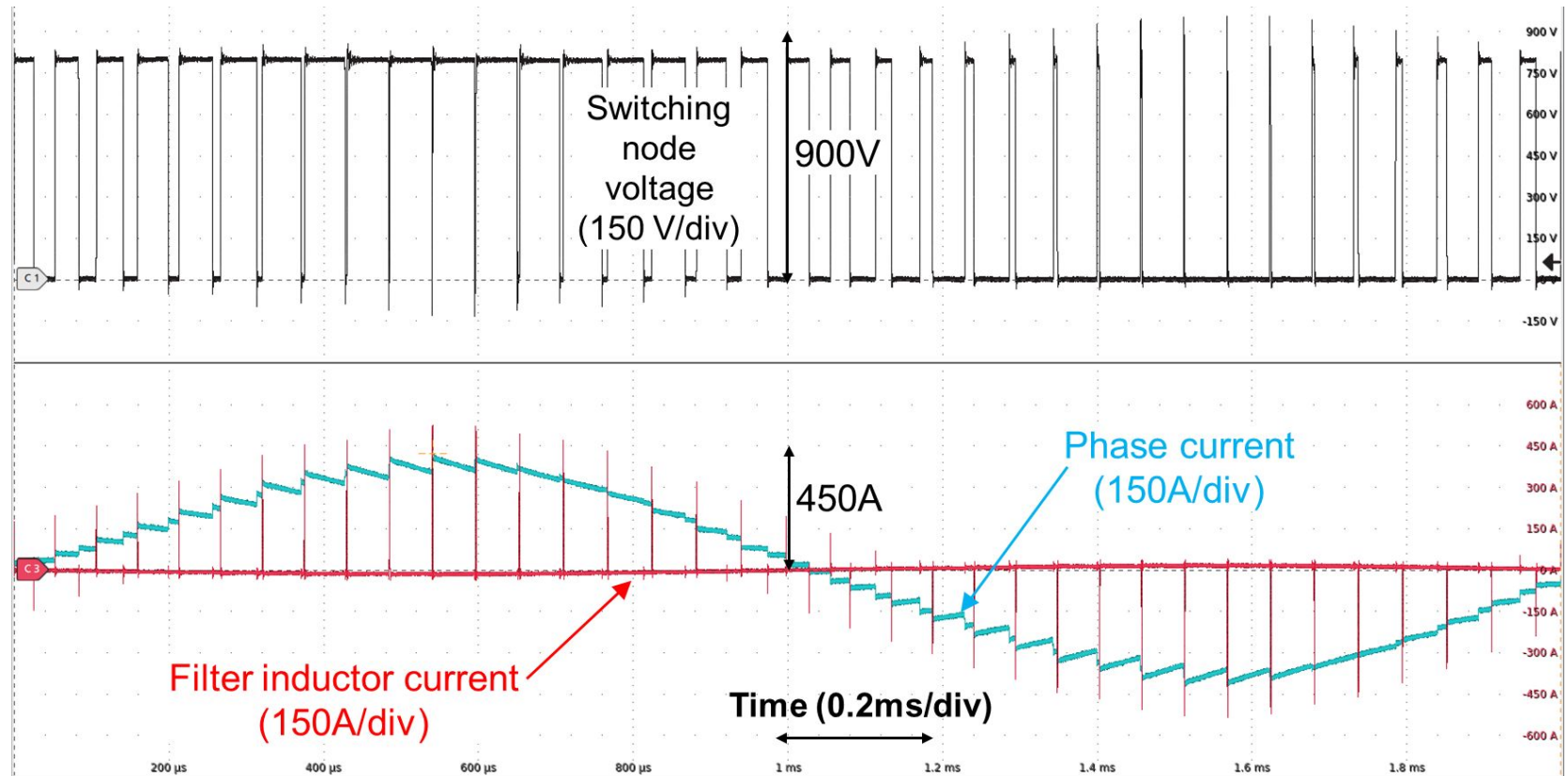
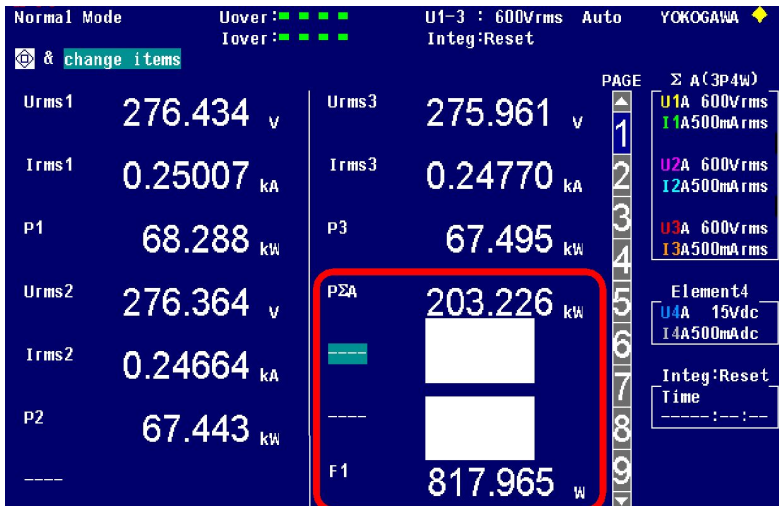

# Experimental Results of Efficiency verse Output Power

- Experimental results verified ultra-high efficiency of inverter with dv/dt filter over wide load range under the conditions of 800 Vdc and three-phase 270 V<sub>RMS</sub> AC output

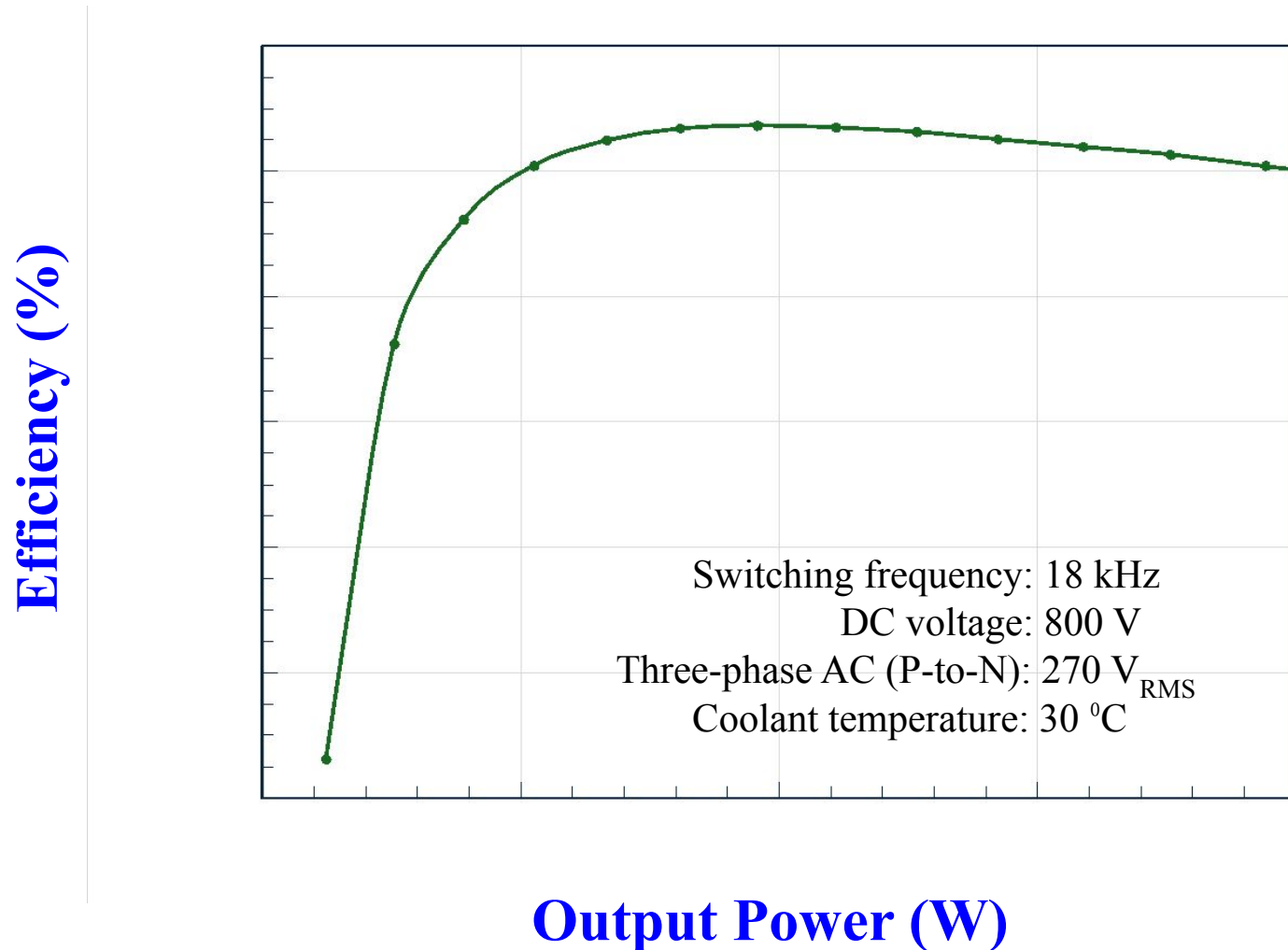

Output Power (W)	Power loss (W)	Efficiency (%)
12320	167.1	98.66
25600	174.1	99.32
38987	187.2	99.52
52653	207.1	99.61
66637	234.7	99.65
80768	269.7	99.67
95762	315.0	99.67
110912	367.4	99.67
126646	429.9	99.66
142300	499.1	99.65
158712	576.5	99.64
175625	659.9	99.63
193981	764.0	99.61
203226	818.0	99.60

# High Efficiency for Wide Range of Voltage/Current

- Efficiency contour map based on 144 experimental points

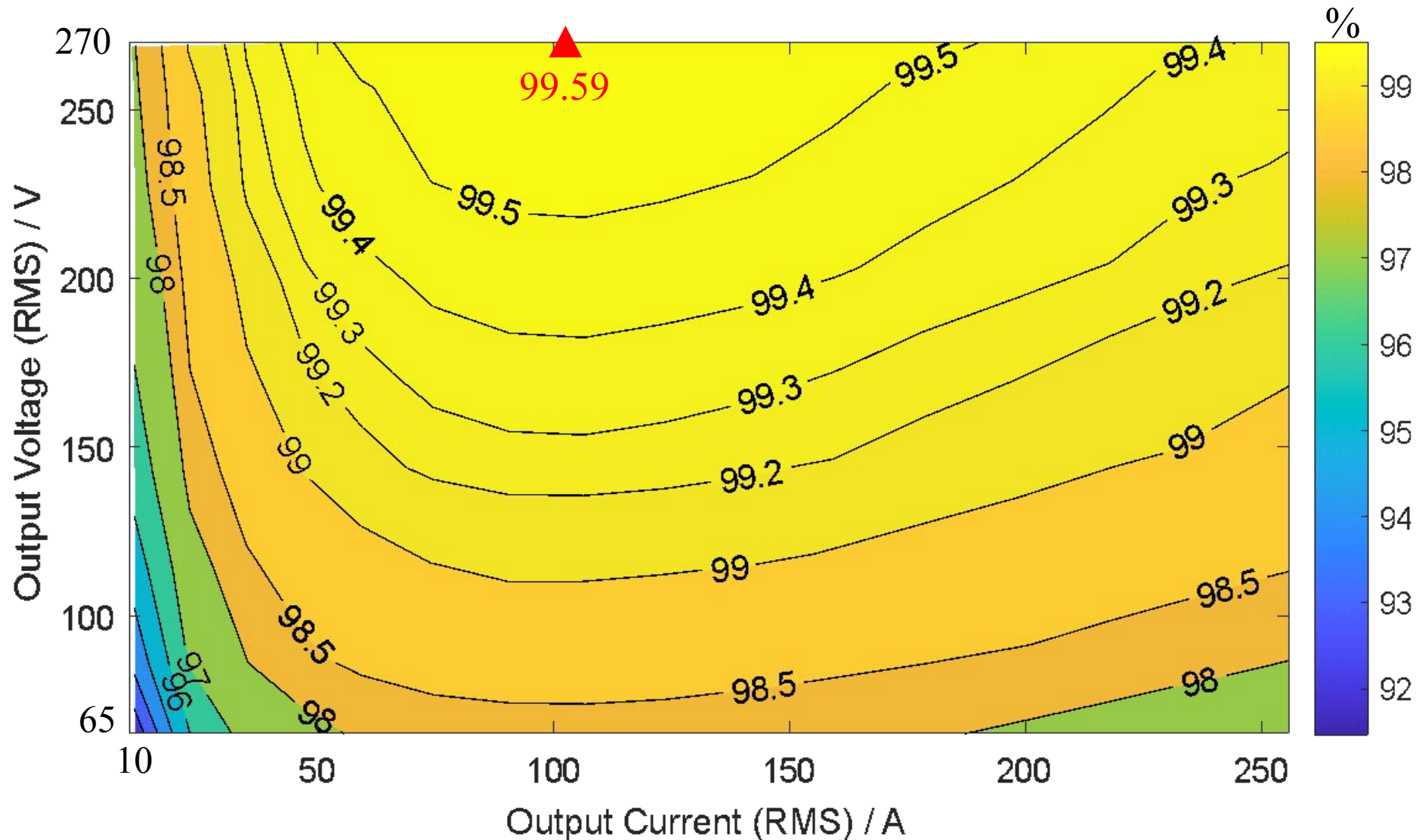

# Experimental Results at 200kW Three-Phase Full Power

- $V_{dc}$ : 800V
- Modulation index: 0.95
- $V_o$ -rms: 270V
- $I_o$ -rms: 250A
- Output frequency: 500Hz
- Switching frequency: 18kHz

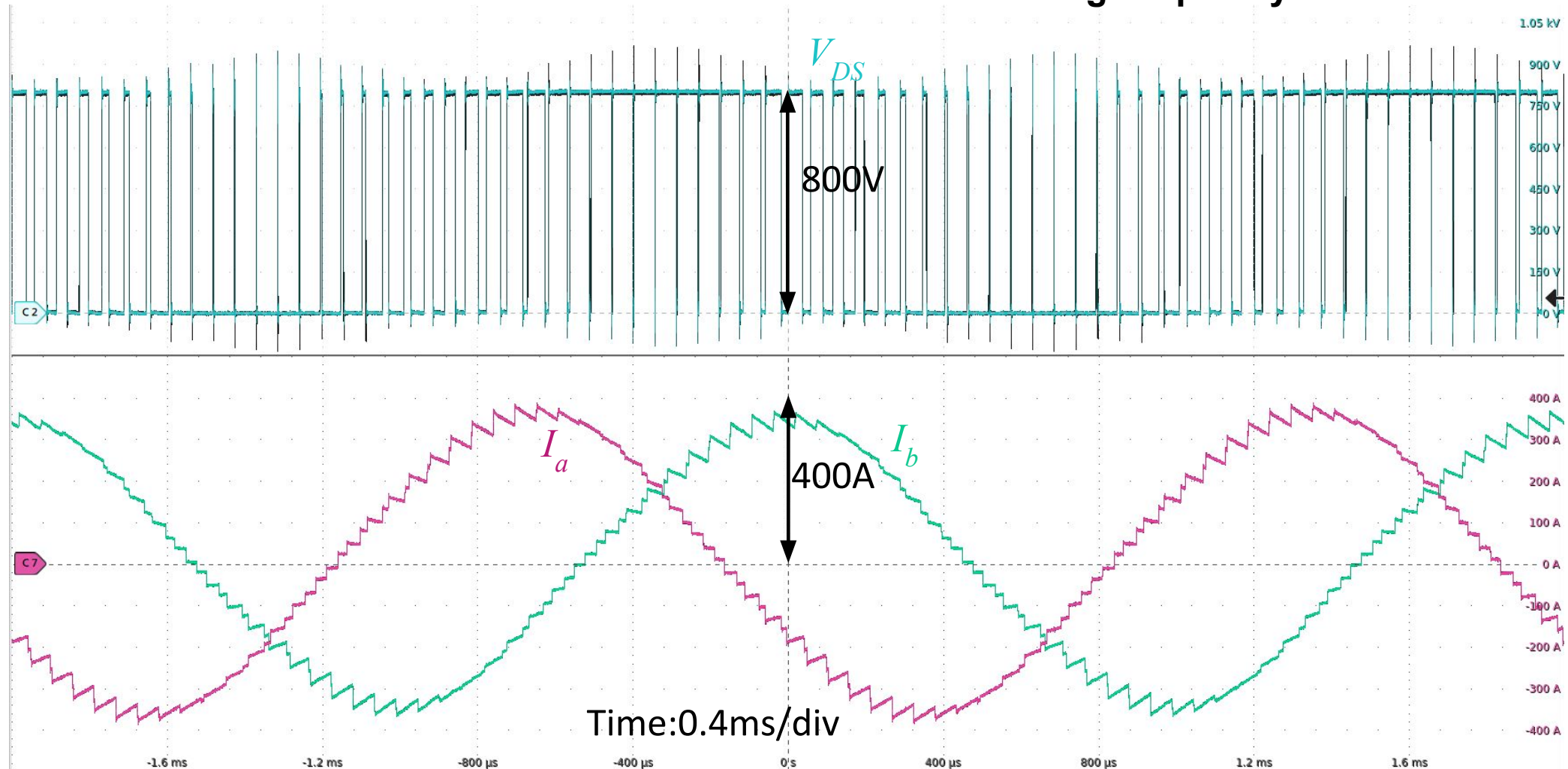

# Conclusion

---

- **dv/dt problem in high-power SiC inverter has been successfully solved by **sub-cycle active damping** technology with **10X reduction in volume** compared to state-of-art dv/dt filters.**
- **A **200kW three-phase SiC inverter** has been demonstrated with a significant improvement in dv/dt control from 50 kV/ $\mu$ s to below **6 kV/ $\mu$ s**, while achieving remarkable efficiency (**99.67% at 110 kW** and **99.60% at 200 kW**) .**
- **This ultra-high efficiency SiC inverter is **highly versatile**, suitable for a wide array of applications, including traction inverters, solar inverters, data center front-end converters, battery energy storage systems, and high-power EV chargers.**

# Related Posters from Our Team

PhD Student	Poster Title
Tanvir Ahammed	Decoupled Digital Control of Isolated C-DC Converters Using Integrated DAB With Interleaved Buck Topologies
Mohammad Mahinur Rahman	Regenerative Efficiency Evaluation of Dual Active Bridge Converters in Medium-Voltage Applications
Mahmoodreza Eskandarpour Azizkandi	Bidirectional Isolated DC-DC Converters with Ultra-Wide Gain Range for Universal EV Chargers
Haris Ataullah	Shared-Switch Hybrid DC-DC Converter for 3-in-1 EV Applications
Tohfa Haque	Power Electronics Building Blocks Using 2 kV Discrete SiC MOSFETs for 1MW SST
Mahmoodreza Eskandarpour Azizkandi	Transformer Design with Enhanced Ap Method using Readily Available and Customizable Magnetics in DAB Converters for Wide Range EV Chargers