

Large Load Modeling for Grid Impact Analysis

Ning Lu

Electrical and Computer Engineering Department

NERC “Large Load” Definition

“Any commercial or industrial individual load facility or aggregation of load facilities at a single site behind one or more point(s) of interconnection that can pose reliability risks to the BPS due to its demand, operational characteristics, or other factors”

What are the large loads?

Category	Typical Large Loads	Main Characteristics
Industrial Large Loads	Metallurgy, chemical plants, mining, semiconductors manufacturing, etc.	High power, continuous or heavy-duty operation
Infrastructure Loads	Metro, high-speed rail, water & sewage plants	Regional concentration, time-sensitive
Hospitals & Communication Hubs	Large hospitals, telecom centers	Critical life-safety loads
Interruptible Large Loads	Arc furnaces, flexible manufacturing	Power-intensive but stoppable
Commercial Large Loads	Malls, office complexes, stadiums	Peak-demand driven (HVAC dominant)
New-Types of Large Loads	Cryptocurrency Mining Data centers (IDC)	High power density, strict reliability
	Hydrogen Production, EV charging hubs	High power density, Operational flexible

**In ERCORT
Loads > 75MW.
More than 100 GW
in the queue.**

What are the impacts of large loads?

- They are generally ≥ 75 MW (Data Centers can be > 1 GW)
- Require a **Large Load Interconnection Study (LLIS)**
 - May require **new transmission upgrades or multiple substations**
 - May need **onsite generation > 100 MW for meeting reliability, adequacy, and stability requirements**
 - May need **UPS, super capacitors, battery storage for backup power**
- **Impacts**
 - Large load variations can induce generator **oscillations** and uncontrolled tripping
 - cause local **voltage depressions (power quality issues)**
 - may trip during normally cleared faults.
 - cause large **voltage disturbances** and **frequency** overshoot, resulting cascading failure
 - Increasing the need for fast frequency response (FFR).
- **Avoid load dropping/increasing “too much, too fast”**
 - **Voltage ride-through** capability is required (e.g., 9-cycle fault clearing).
 - A minimum remaining-on capacity may be required post-fault to prevent cascading disturbances.
 - For example: 1GW data center should have say a minimum of 500 MW remaining after the fault is cleared or limiting the load changes to be within 200MW.
- **Require new dynamic load models.**

Planning and Operational Issues

Where to put generation/CAP/UPS/battery resources? Capacity of them? Coordinations?

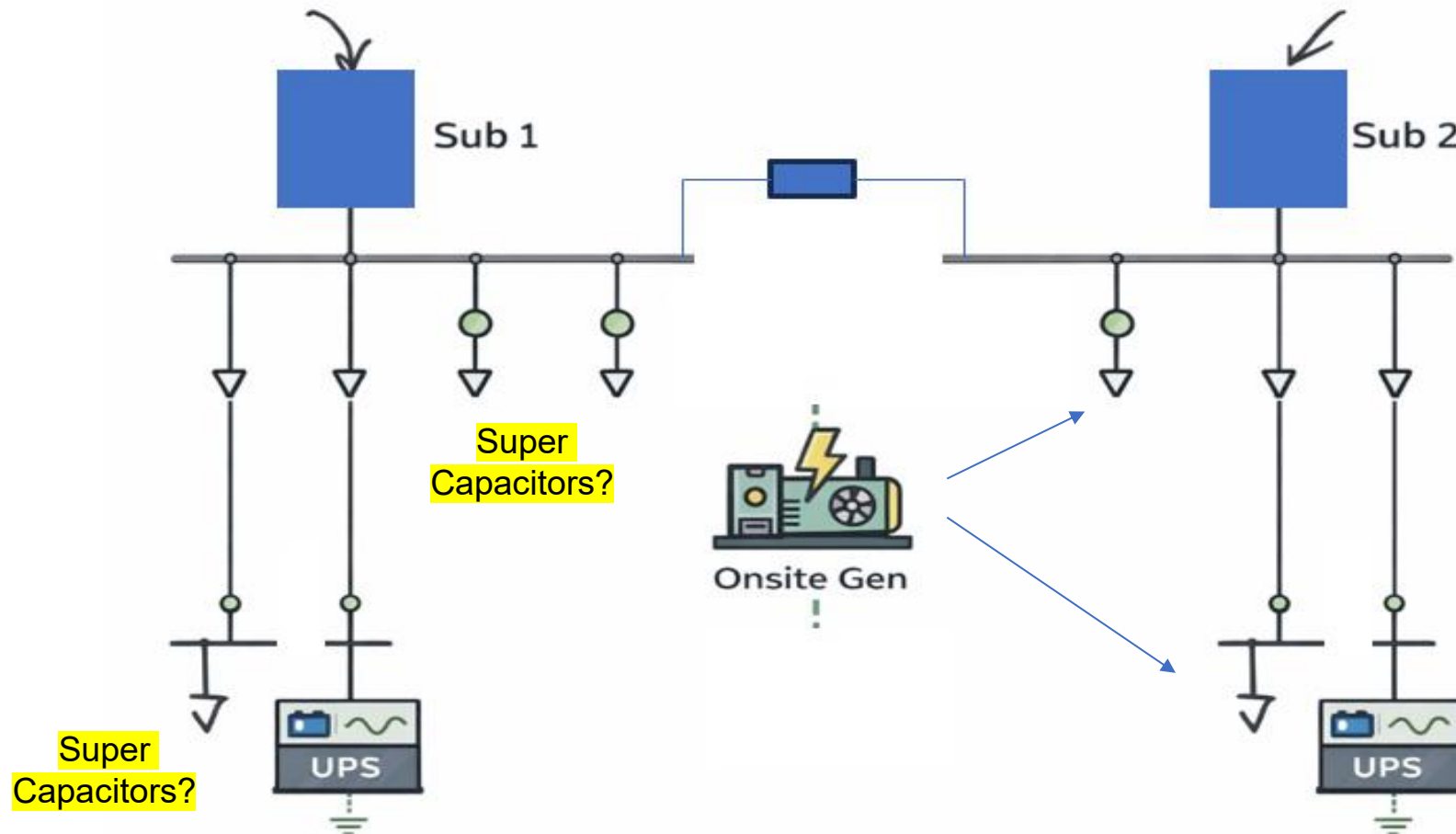

What load characteristics may be desired?

- The dynamic response of **Large Load Interconnection Study** may evaluate:
 - Frequency nadir / overshoot
 - Rate Of Change Of Frequency (ROCOF)
 - Voltage recovery
 - Generator responses
- We may need to specify
 - Maximum instantaneous load loss (MW)
 - Minimum post-fault retained load
 - Required staged shedding (e.g., blocks of 50–100 MW)
 - Load ramp-down / ramp-up rates

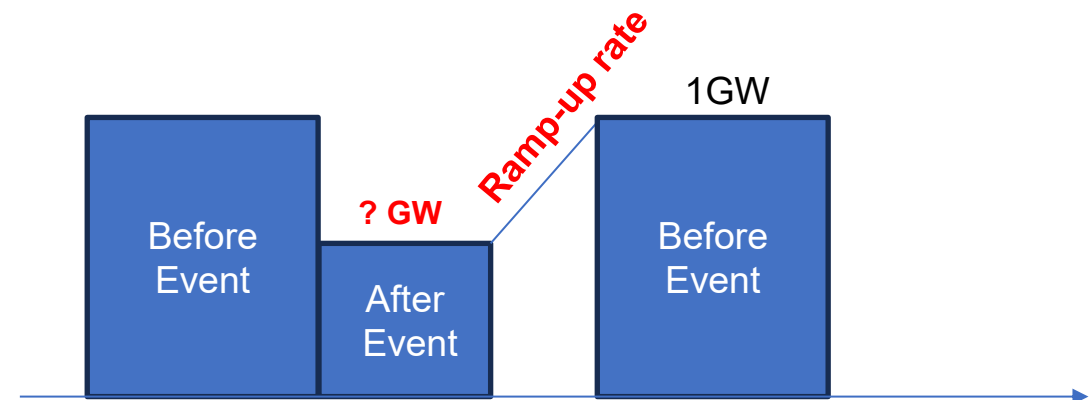
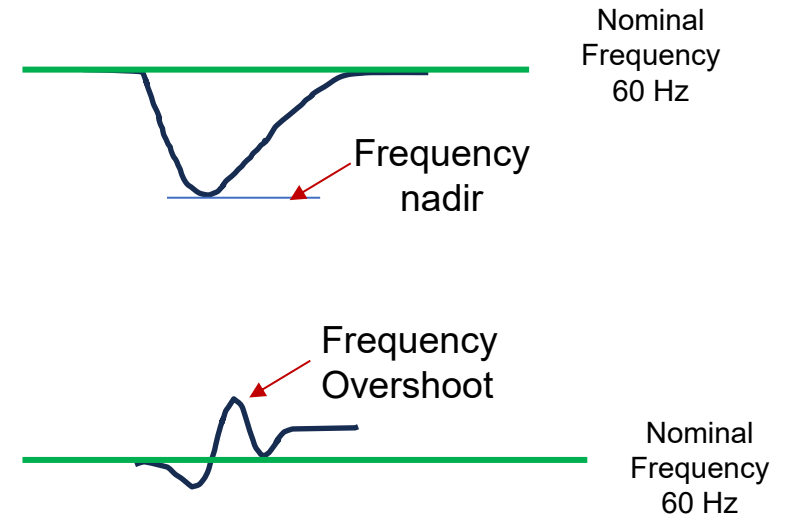

Dynamic Load Models for a Data Center

Category	Typical Large Loads	Main Characteristics	Typical Load Models
Data Centers (IDC)	AI Training, Cloud computing,	High power density, near-constant load, high power quality	ZIP (P-dominant), Motors, Large synchronous Generators, UPS, Super Capacitors, IBRs: Batteries, PV farms, etc.
EV Charging Loads	Fast charging stations, fleet depots	Highly stochastic, clustered demand, power electronics dominated	Constant Power (P)+Power Electronics
Commercial Building Loads	Office complexes, malls, stadiums	Strong daily/seasonal variation, HVAC-dominated	ZIP models (Z + I dominant), aggregated motor models

Integrated T&D Models

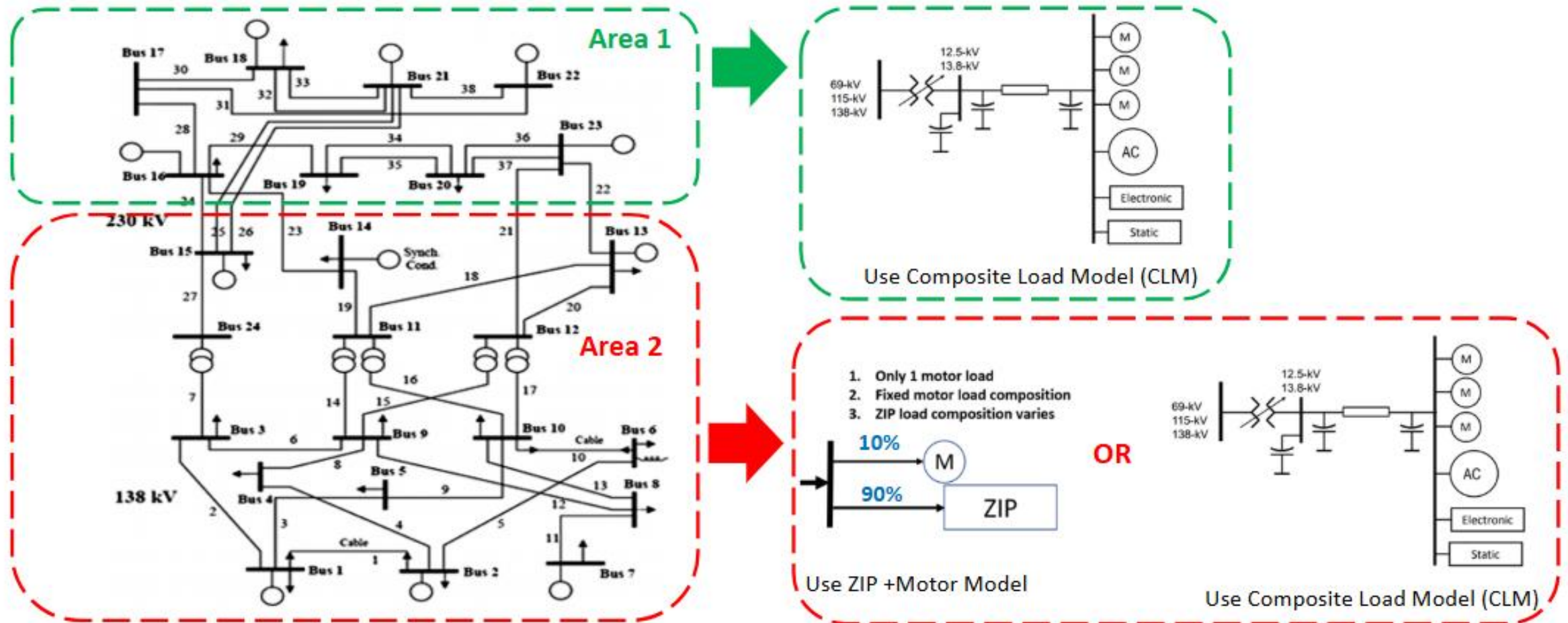

A Digital Twin based Approach

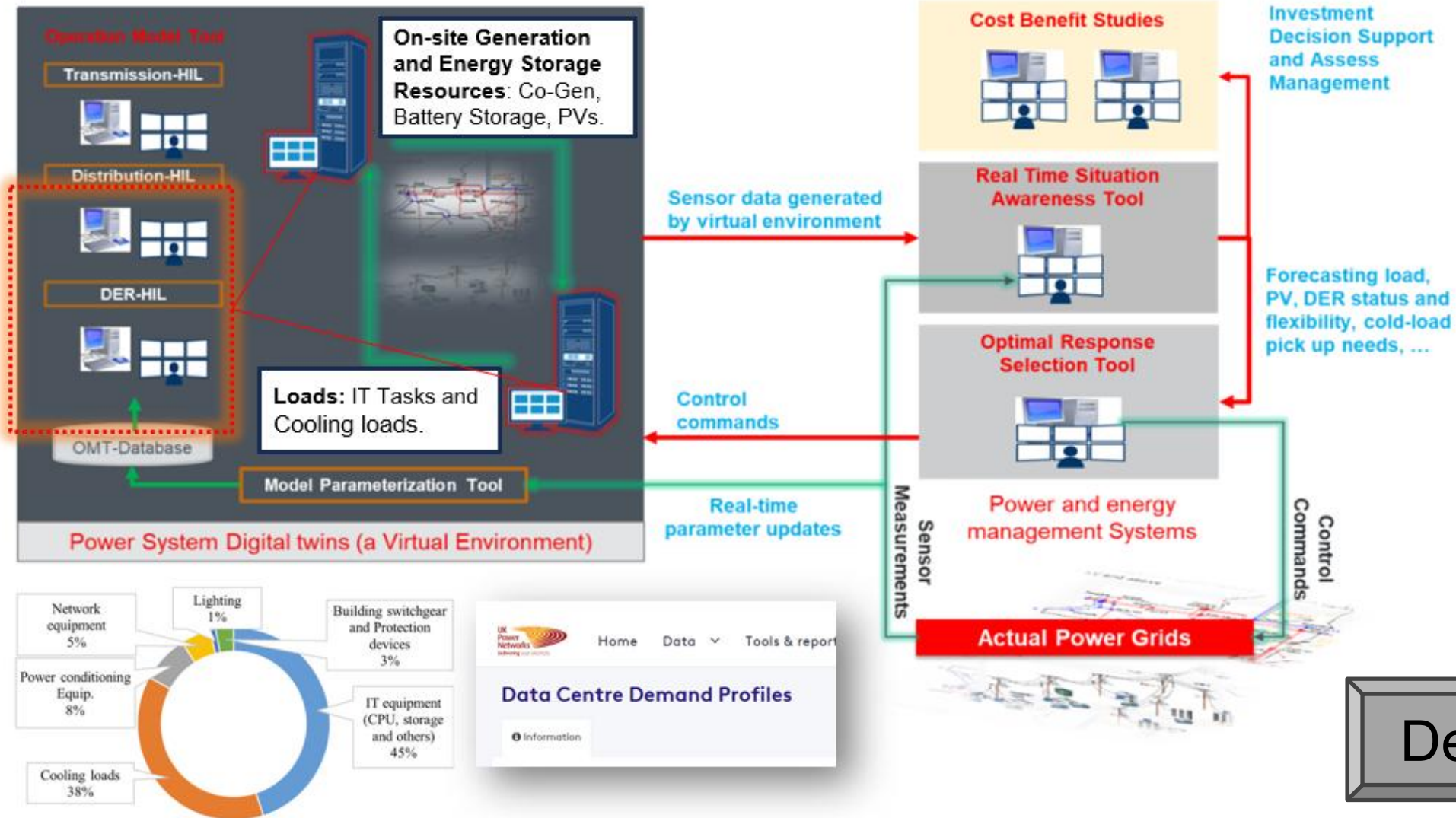

Demo

Our Existing Microgrid Digital Twin Layout

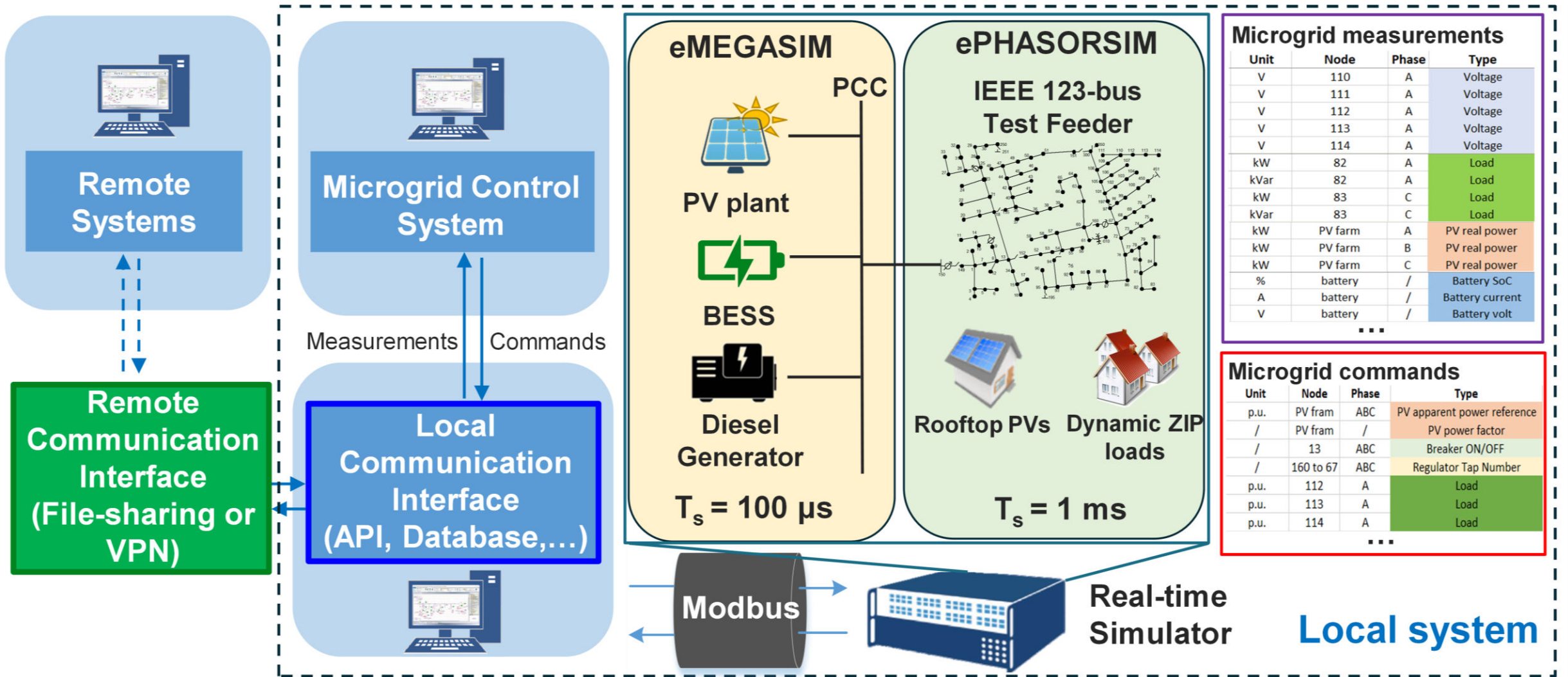

Data Center Digital Twin Layout

- 5) Short-term Load Forecasting
- 6) Energy Management
- 7) Adaptive IT Workload Scheduling

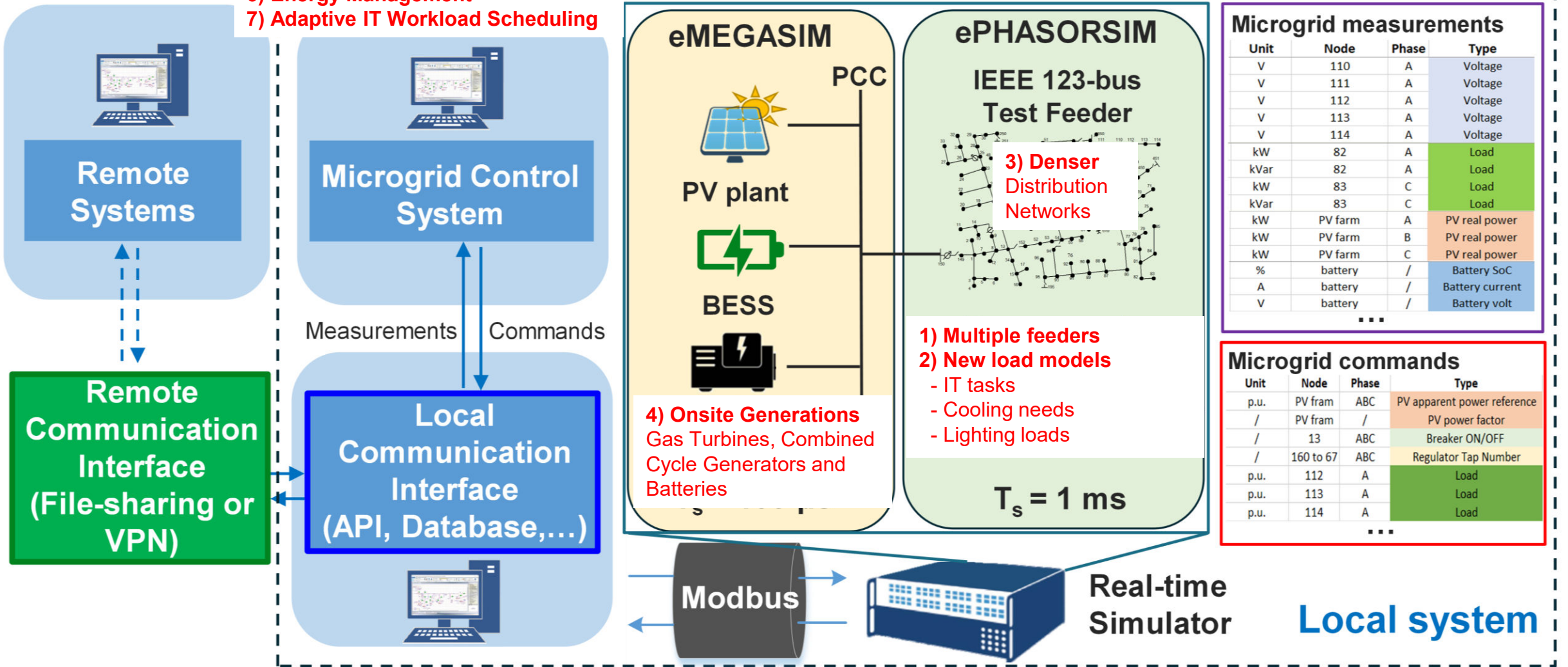

Integrated Simulation

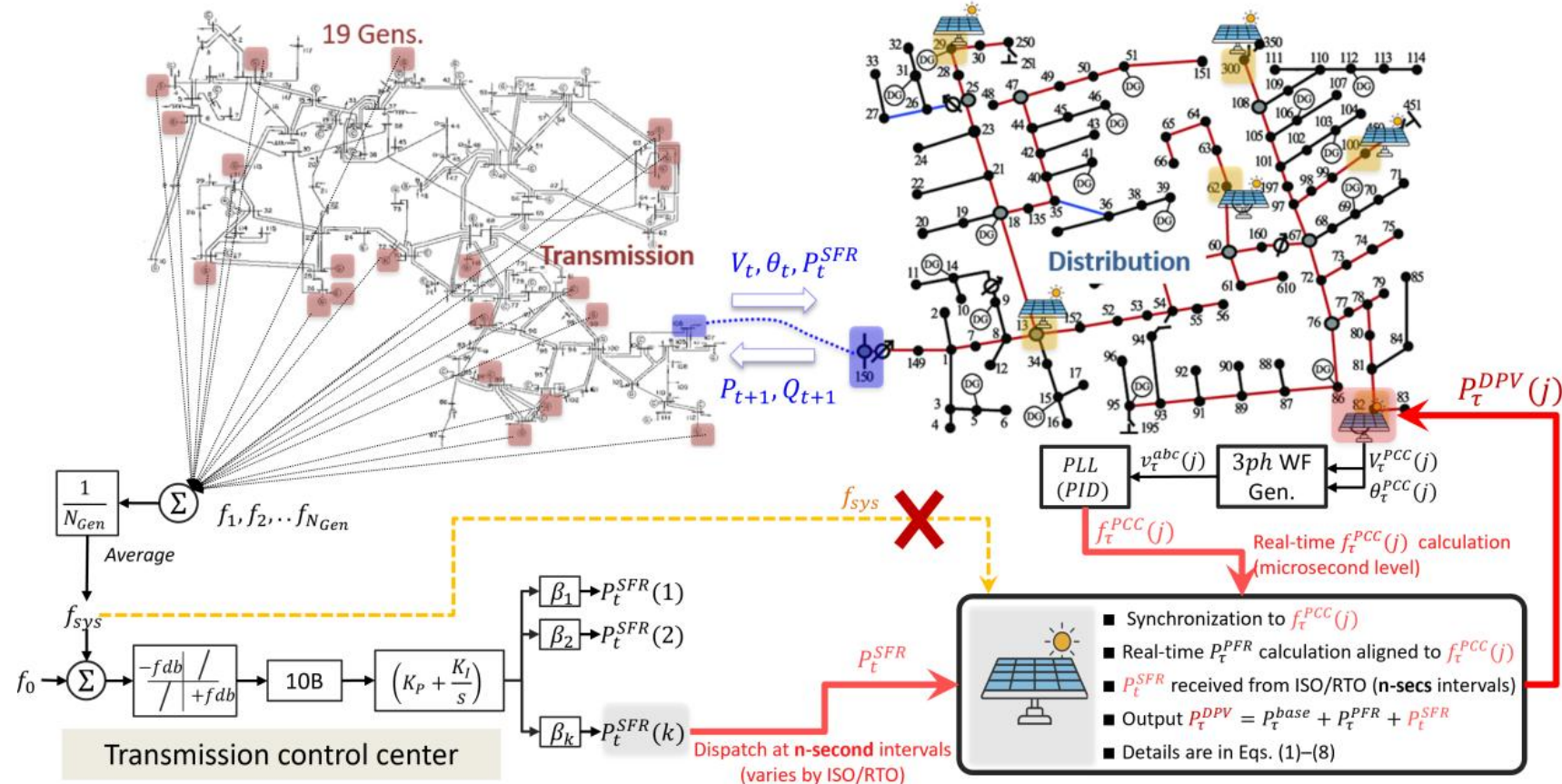

Title: [Accurate Frequency Response Modeling in Integrated T&D Co-Simulation via RETA-Based Quadratic Extrapolation](#)
 JH Woo, [Q Xiao](#), Y Ma, Z Yang, [VD Paduani](#), N Lu. Available at SSRN 5508821 • [papers.ssrn.com](#)

Load Data Processing

- Enable **automated processing and analysis of data center load data**
- Identify distinct load characteristics and operating patterns
- Accurately model data center load dynamics and transient behavior
- Inform sizing and operational requirements for on-site generation
- Determine on-site energy storage needs, including batteries, supercapacitors, and UPS systems
- Support advanced energy management, control, and optimization strategies

IT computing Load Type 1

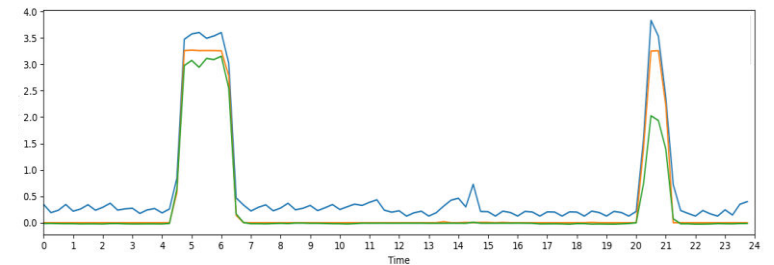

IT Computing Load Type 2

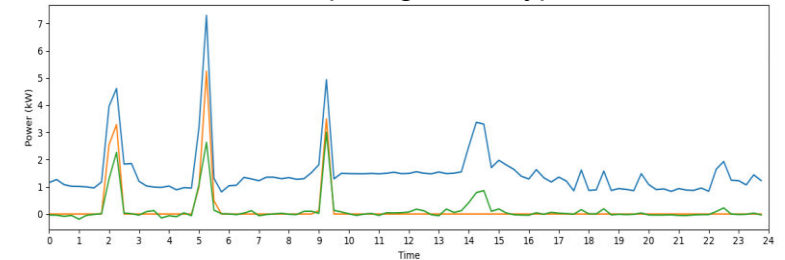

Cooling Loads

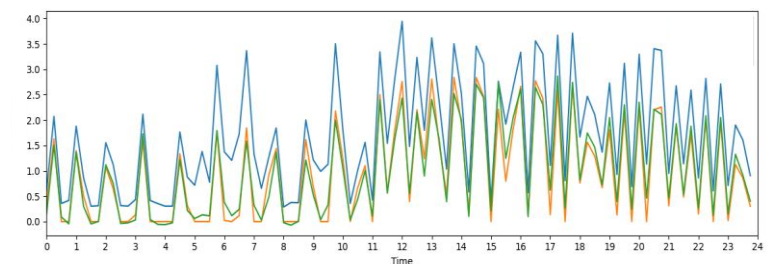

The load profiles are for illustration only

Behind-the-meter load Identification

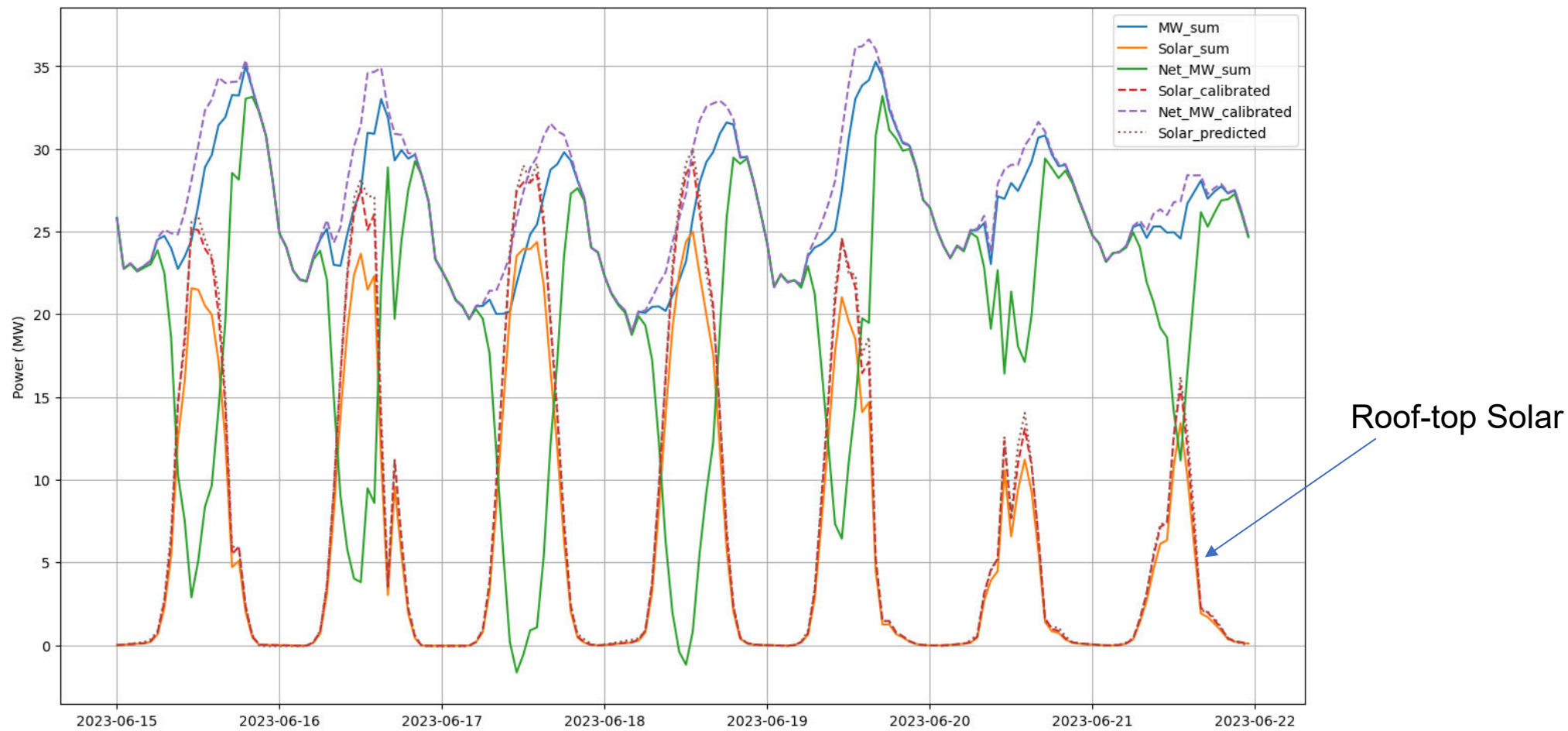

Conclusions

- Data centers require **dedicated modeling approaches** due to their unique load composition and operating characteristics
- **Data-driven digital twin models** are essential to enable scalable, high-fidelity representation
- Modeling should **capture day-to-day operational dynamics**, rather than static or snapshot-based behavior
- **Modular model** designs are needed to flexibly address diverse data center architectures and use cases
- **Seamless integration** with large-scale power system models is critical for assessing grid interconnection and system-level impacts