

FLEXGEN



BESS FOR DATA CENTERS

Smoothing

Flexibility

Backup

Firming



HybridOS Software

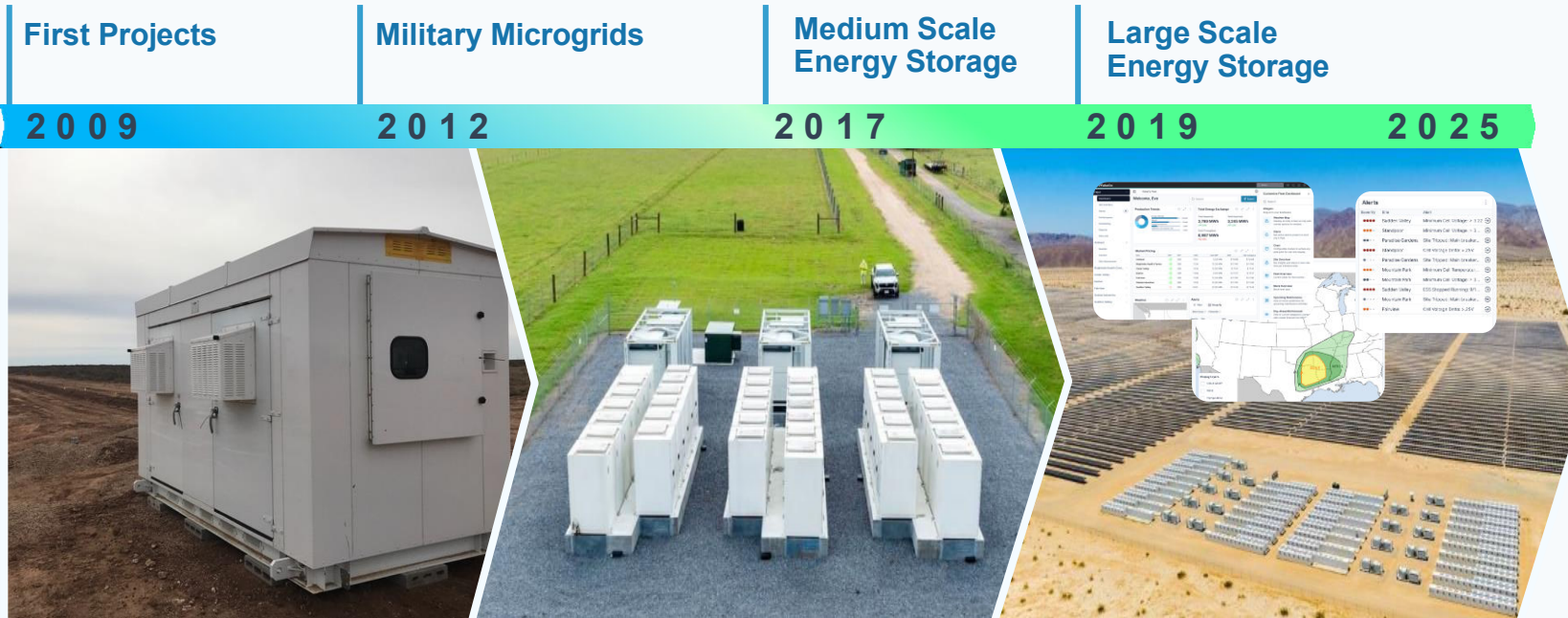

Flexibility

We don't make hardware.
We make hardware work.
Universally compatible with top tier OEMs and optimizers.

Predictability

AI-Assisted Innovation Lab for accelerated, predictable One-Touch Commissioning

Availability

98% Site Uptime driven by user-friendly, American-Made HybridOS software (EMS | PPC | Site Scada | Controls | Analytics)

Accountability

Bankable, profitable, responsive single point of accountability for the full decade+ BESS lifecycle, from development and engineering to procurement and integration to performance and operations

Digital Demand = Energy Demand

- 2023 - 2030
- 152,120,846 MWh → 214,049,306 MWh
- 41% Growth, ~62TWh/y

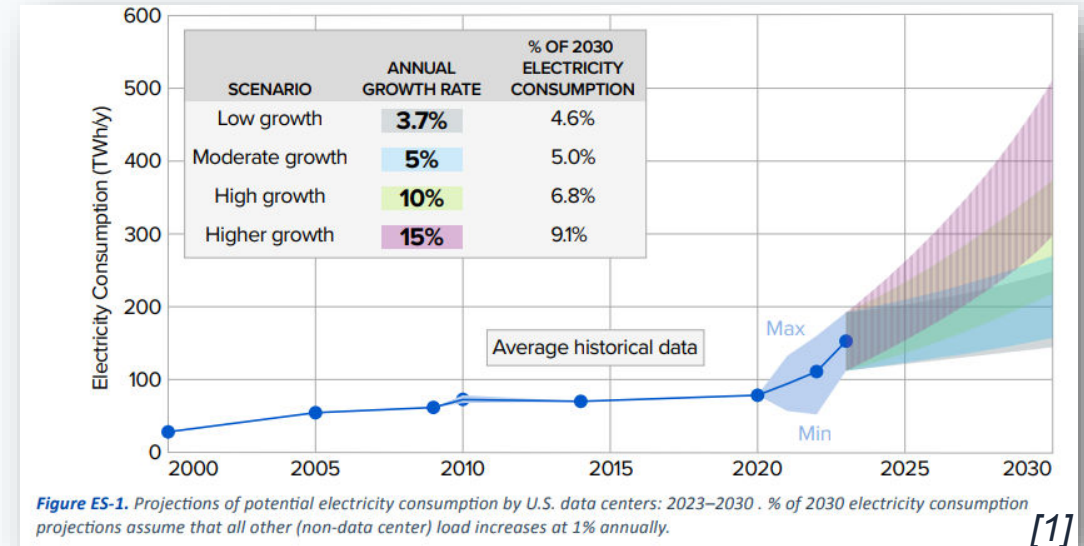
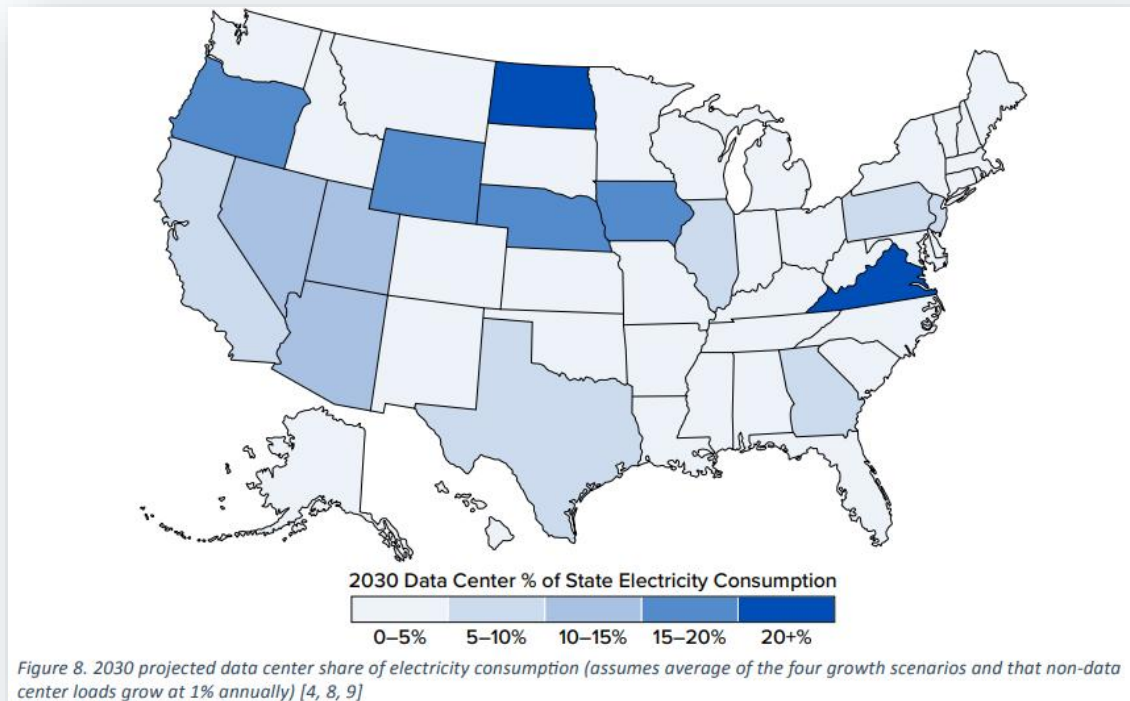

Smoothing & Ramp Rate Control

- AI workloads exhibit periodic behavior
- Consisting of lower frequency work/communicate cycles, with higher frequency variations while working.
- Likely not compliant with any interconnection agreements when applied at scale
- Even more tame workloads would benefit from smoothing as well
- Challenging load for local generation.
 - Sub Synchronous Resonance risks
 - Torque disturbances/ripples
 - Damage/Fatigue at resonance
- 20% - 90% Ramps (Or more)
- Gridforming BESS can smooth ~70%+
- Line Interactive
- Power Conditioning
- Double Conversion

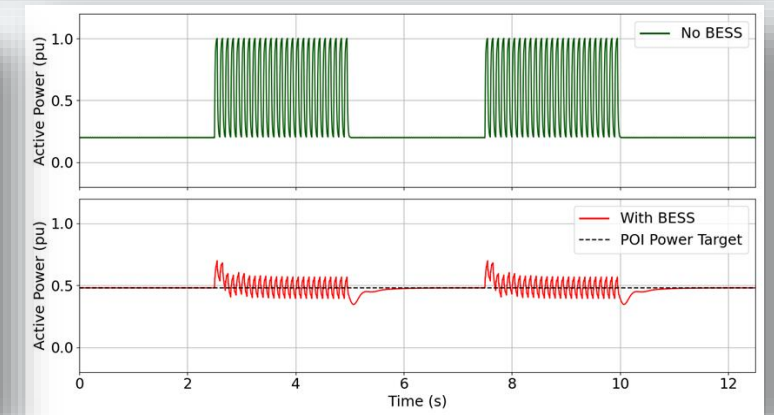
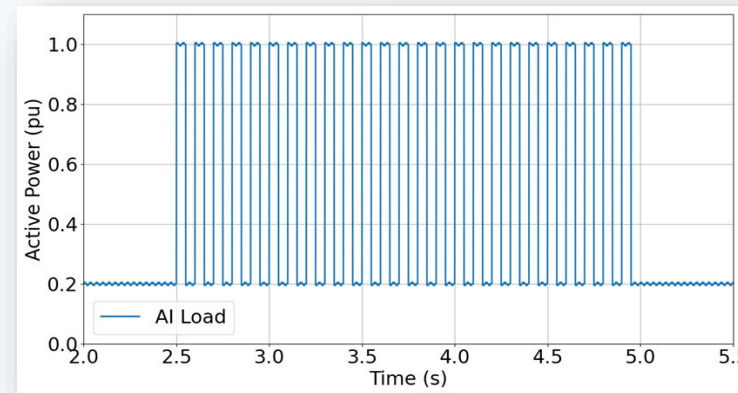
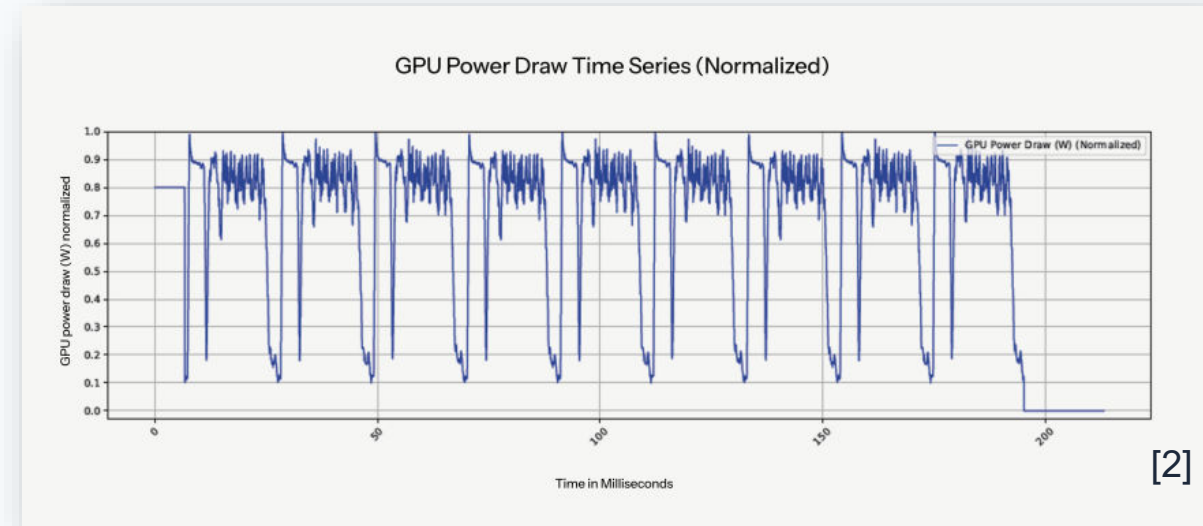

GridForming BESS

- Inverter performs GFM function control (VISMA)
- Reacts to support V,f within ~2-3 cycles (<50ms)
- Performance highly dependent on system (Impedance Split, grid strength, etc)
- Smoothing can be as good as ~70%
- ~55% in simulation below

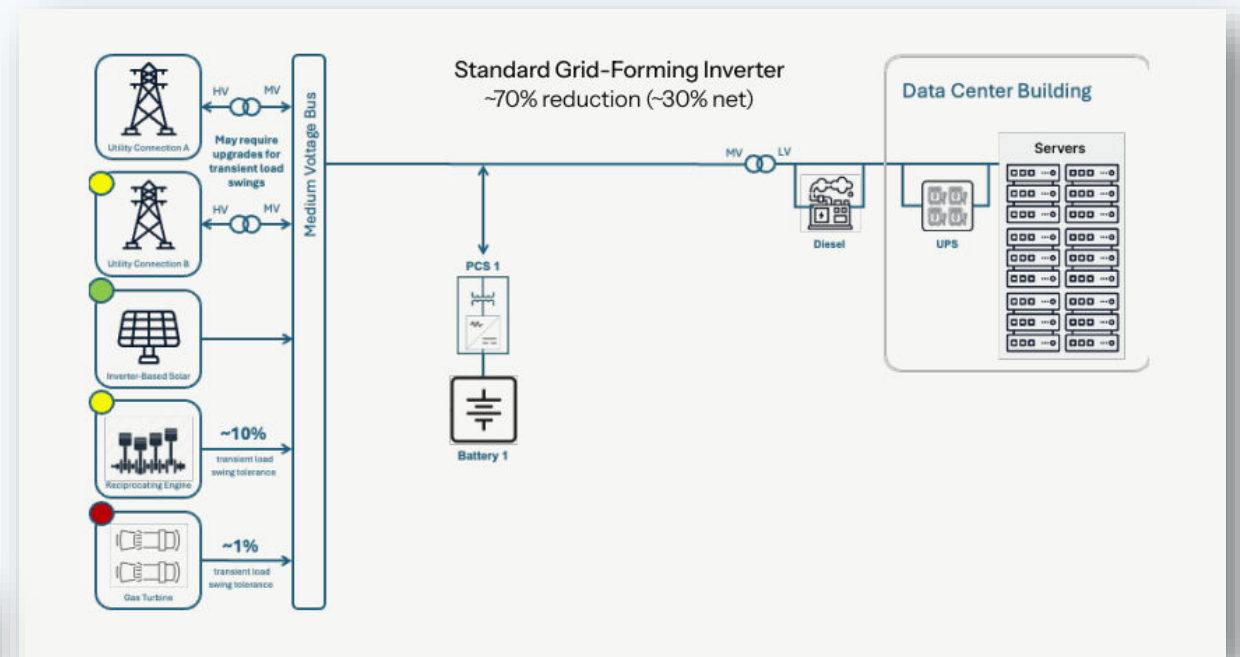
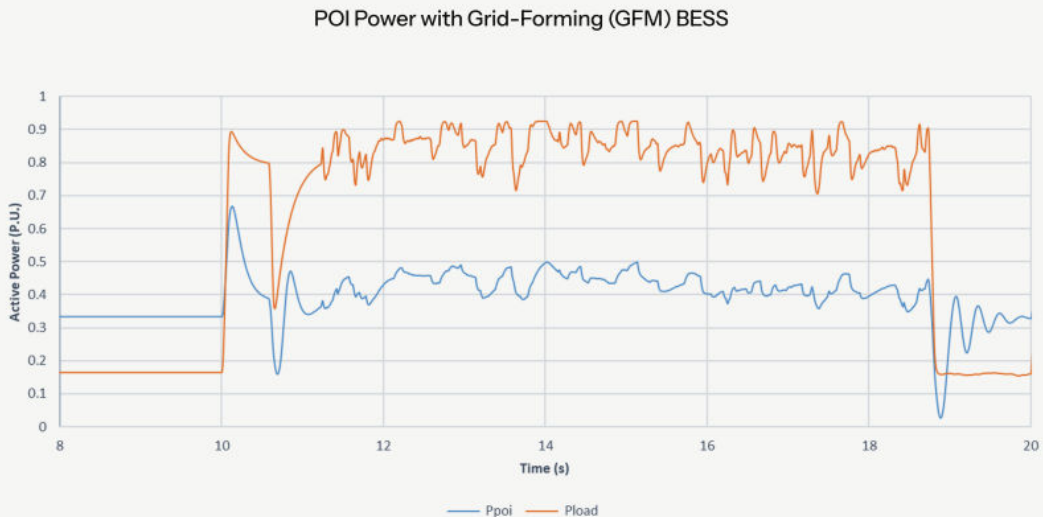

Conceptual Single Line Drawing of data center with a grid forming (GFM) inverter

- Paralleled with Grid/Load
- Tied in at Medium Voltage 34.5kV
- Could be sited as traditional BESS plant

Line Interactive

- Inverter performs GFM function control (VISMA)
- Reactor between Grid and BESS, Load
- Reactor helps with Impedance Split, BESS can manage more of the load variation
- Smoothing can be ~80-90%
- ~80% in simulation below

POI Power with Line Interactive BESS

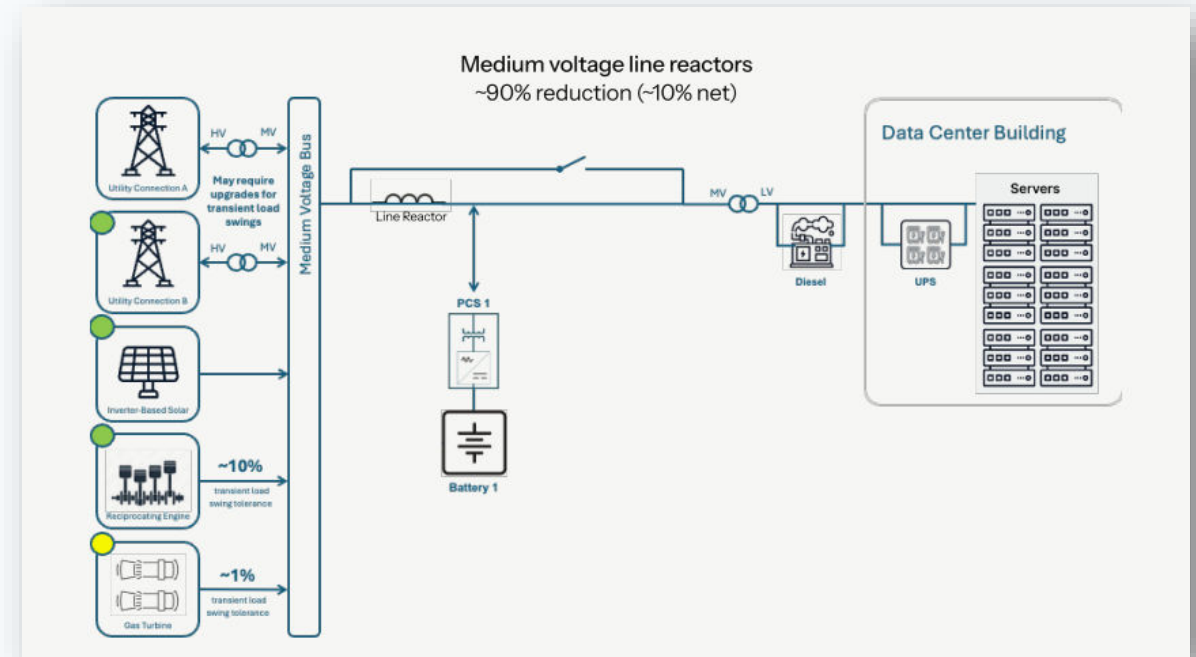
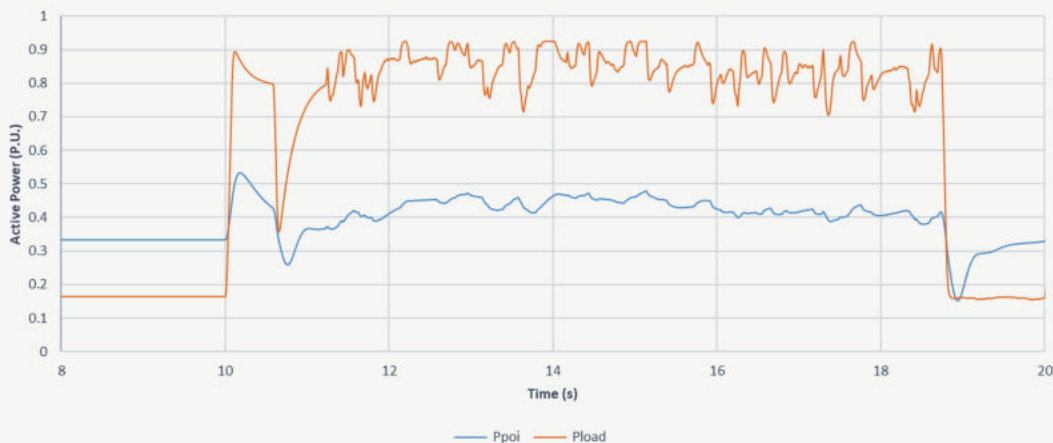

Conceptual Single Line Drawing of line-interactive structure

- Could be sited in blocks / feeder groups. More distributed
- Reactor helps smooth transients, improving power quality and improving island transitions
- Reminiscent of an older idea (DRUPS/Flywheels)

Load Sensing / Power Conditioning

- Inverter performs GFM OR GFL
- Closed Loop Control using a sensor on the relevant bus
- High speed integration of load sensing to inverter controls
- Smoothing can be >95%
- ~95% in simulation below

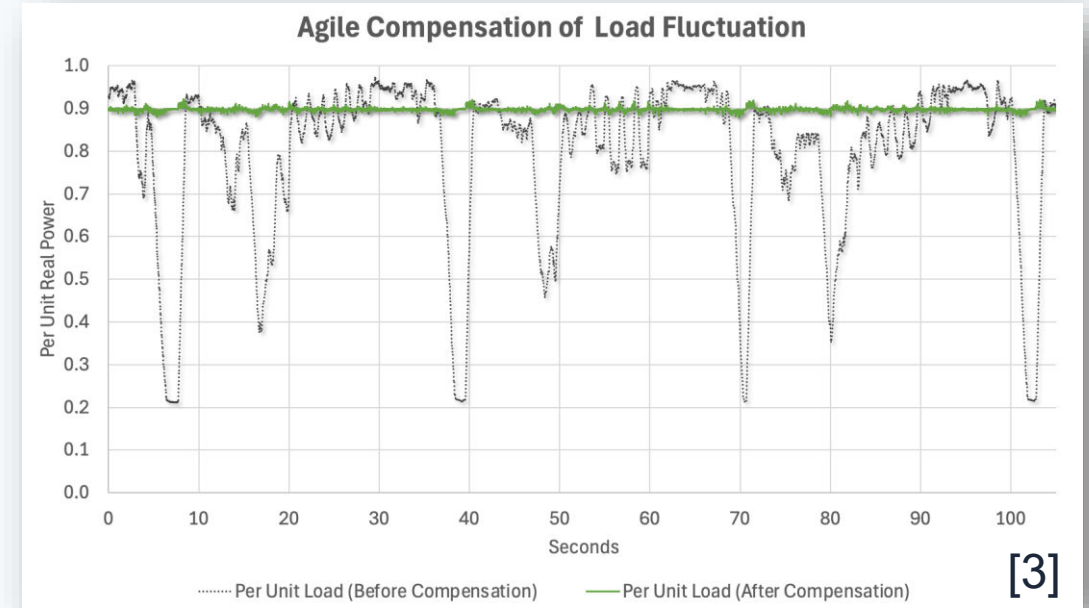

EPC Power Agile Grid Forming BESS Example

- Inverter OEMs beginning to offer this functionality
- Specifically fielded to address load management concerns

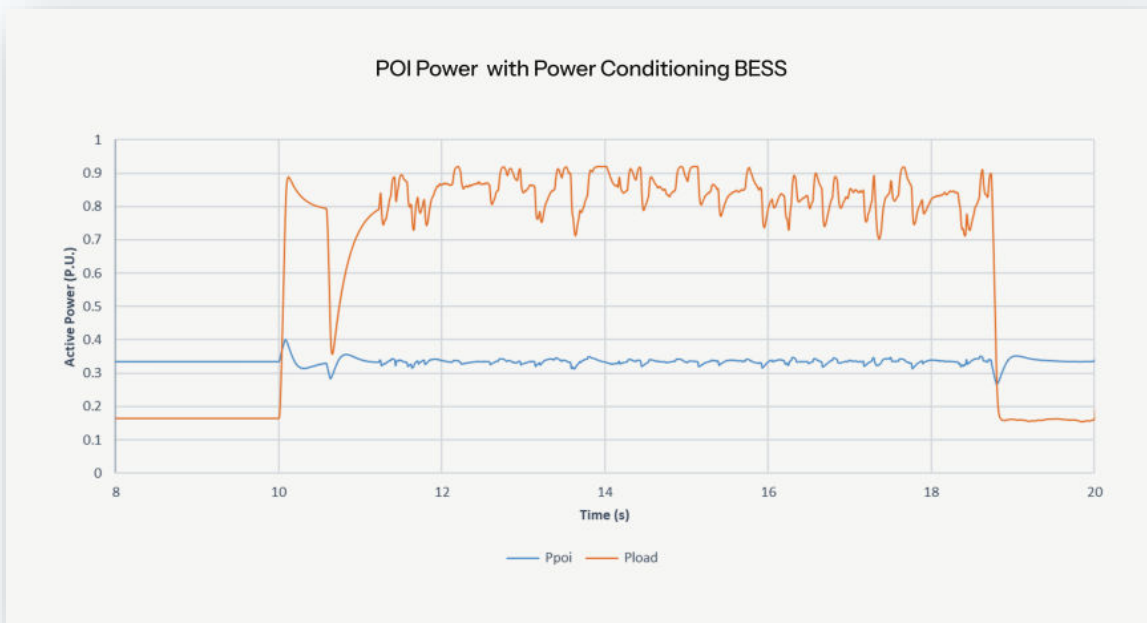

Double Conversion

- Inverter performs GFM/GFM, GFL/GFM
- Load facing Inverter provides stable V,f
- AI profile nearly fully mitigated by conversion
- Smoothing can be >99%
- >99% in simulation below

POI Power with back to back BESS

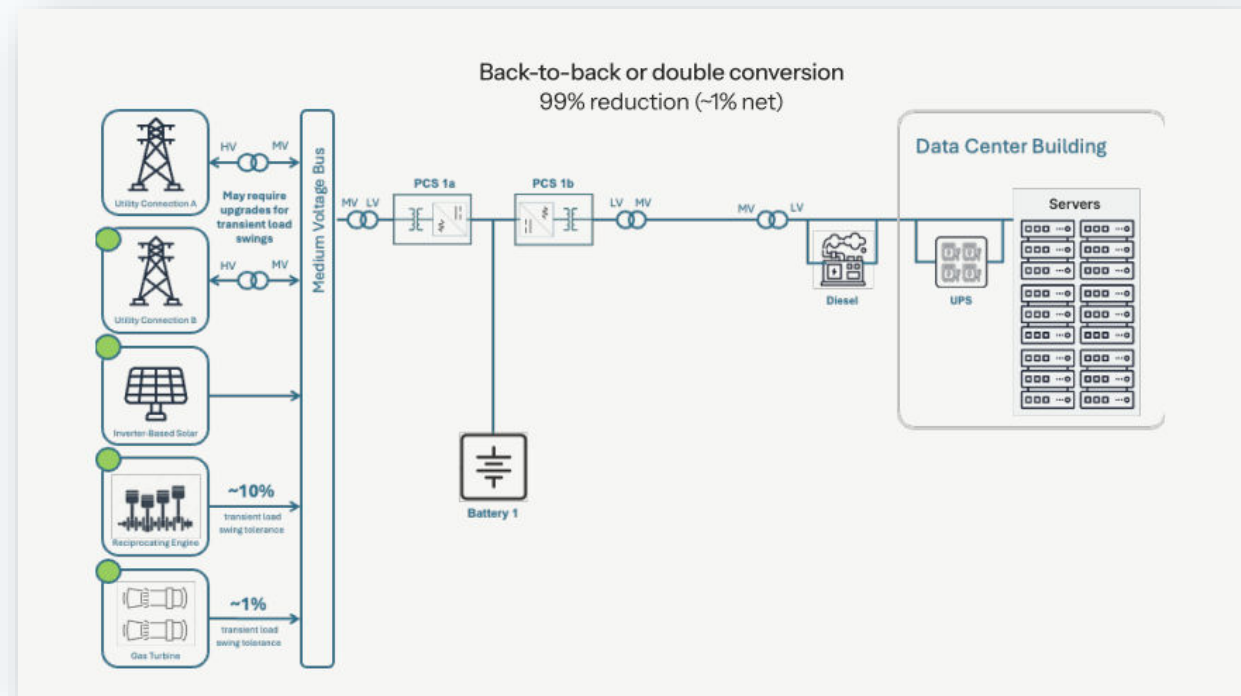
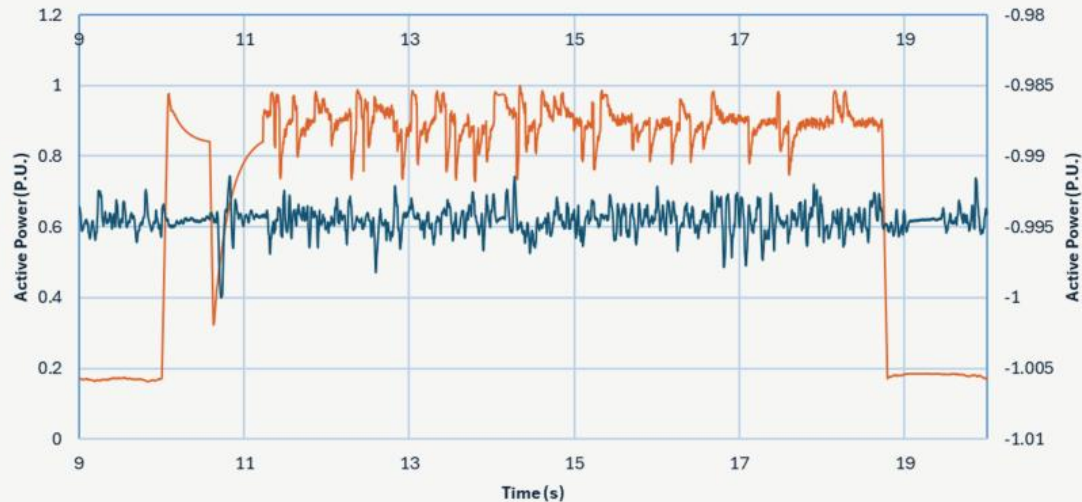

Conceptual single line drawing of medium voltage (MV) back-to-back structure

- Small magnitude of profile couples across DC bus
- Note Grid side P is right axis, Load is left axis
- Excellent isolation

Flexible Interconnection

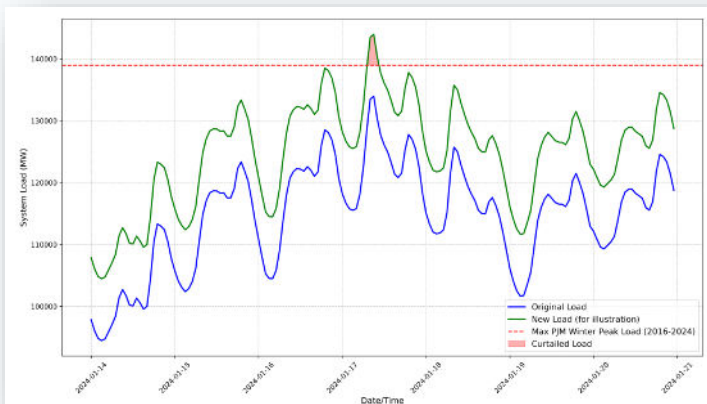
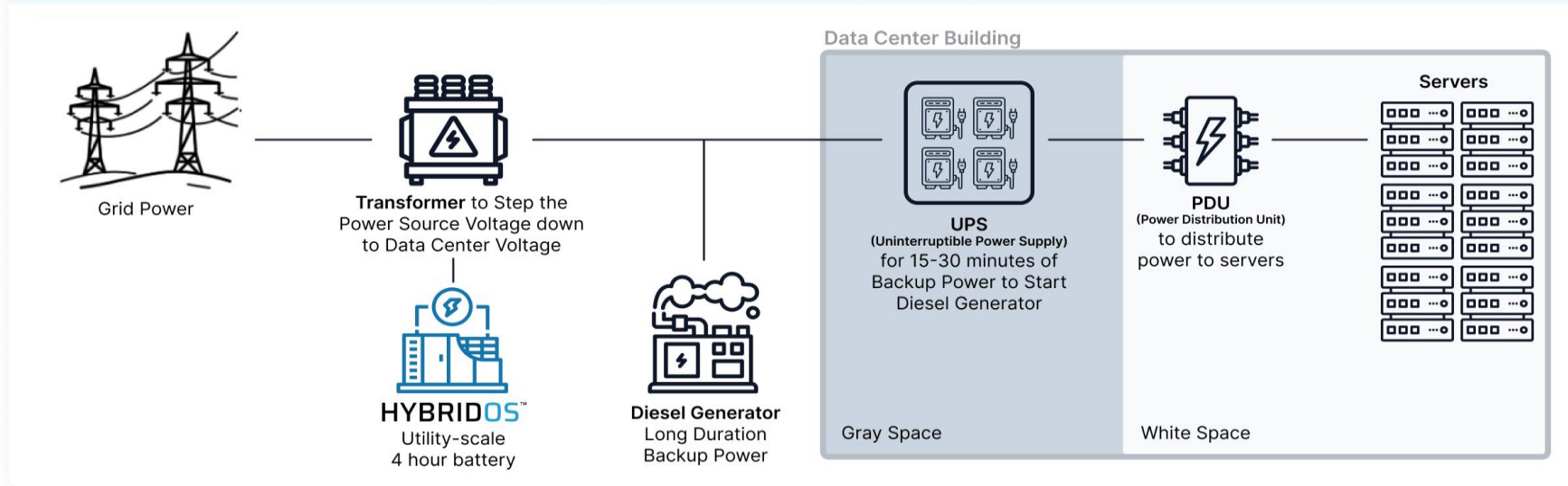

- The average duration of 1.7 hours when load curtailment is limited to 0.25%, 2.1 hours at a 0.5% limit, and 2.5 hours at a 1.0% limit
- 76 GW of new load—equivalent to 10% of the nation’s current aggregate peak demand— could be integrated with an average annual load curtailment rate of 0.25% (i.e., if new loads can be curtailed for 0.25% of their maximum uptime)

Backup

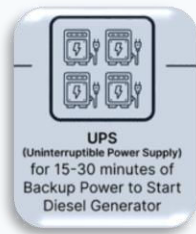
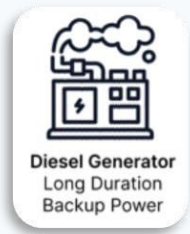
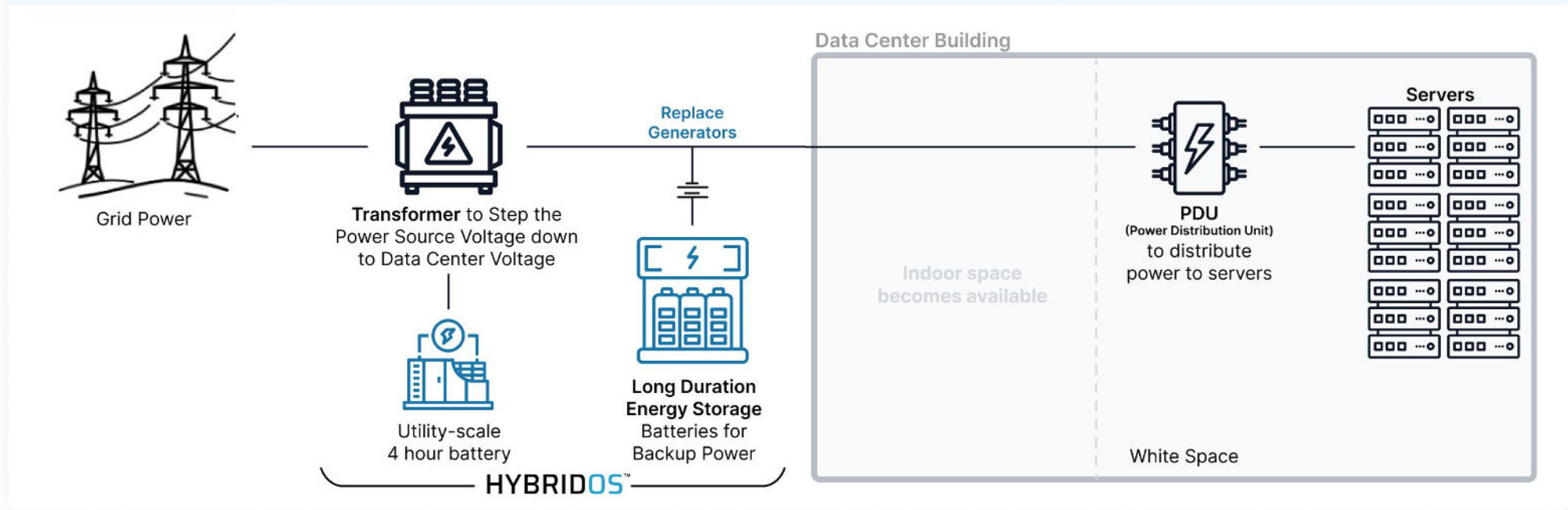

- Line interactive BESS + Reactor
- Reduce or eliminate Diesel runtime
- Fast V,f support with Gridforming

- UPS + BESS
- LVRT requirements

Firming Site Power

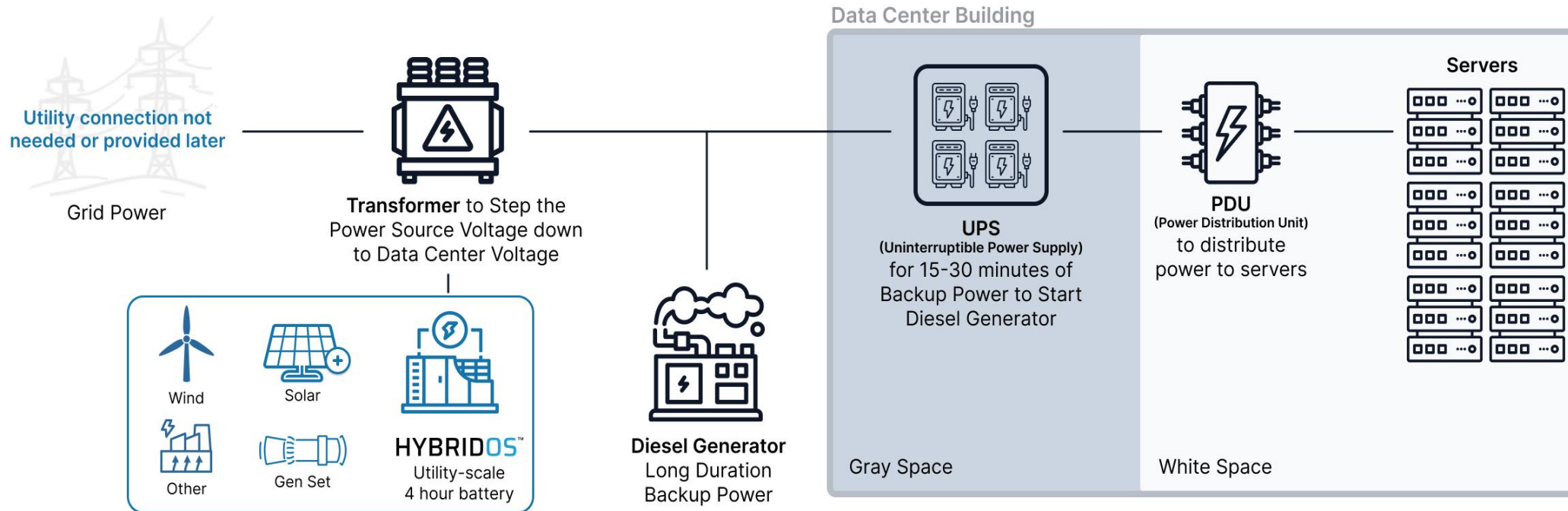

- POI ramp rate control
- Generator bus ramp rate control
- Energy Shifting

- Islanded power balancing
- Renewable Firming
- Gridforming



Thanks!

Ahren Lieth
Director, Systems Engineering

Visit flexgen.com to learn more

HQ: 280 S. Mangum St. Suite 150,
Durham, NC 27701 855-327-5674

